



INTERNATIONAL APPLICATION PUBLISHED UNDER THE PATENT COOPERATION TREATY (PCT)

<p>(51) International Patent Classification ⁶ : A61B 5/00</p>	A1	<p>(11) International Publication Number: WO 99/29230</p> <p>(43) International Publication Date: 17 June 1999 (17.06.99)</p>
<p>(21) International Application Number: PCT/US98/25685</p> <p>(22) International Filing Date: 4 December 1998 (04.12.98)</p> <p>(30) Priority Data: 60/067,603 5 December 1997 (05.12.97) US 60/067,601 5 December 1997 (05.12.97) US</p> <p>(71) Applicant (for all designated States except US): E. HELLER & COMPANY [US/US]; Suite 1000, 1311 Harbor Bay Parkway, Alameda, CA 94502 (US).</p> <p>(72) Inventors; and</p> <p>(75) Inventors/Applicants (for US only): BONNECAZE, Roger, T. [US/US]; 4708 Switch Willo, Austin, TX 78727 (US). FREELAND, Angela, C. [US/US]; 3300 Parker Lane No. 116, Austin, TX 78741 (US).</p> <p>(74) Agent: DAIGNAULT, Ronald, A.; Merchant, Gould, Smith, Edell, Welter & Schmidt, P.A., 3100 Norwest Center, 90 South Seventh Street, Minneapolis, MN 55402-4131 (US).</p>	<p>(81) Designated States: AL, AM, AT, AU, AZ, BA, BB, BG, BR, BY, CA, CH, CN, CU, CZ, DE, DK, EE, ES, FI, GB, GD, GE, GH, GM, HR, HU, ID, IL, IS, JP, KE, KG, KP, KR, KZ, LC, LK, LR, LS, LT, LU, LV, MD, MG, MK, MN, MW, MX, NO, NZ, PL, PT, RO, RU, SD, SE, SG, SI, SK, SL, TJ, TM, TR, TT, UA, UG, US, UZ, VN, YU, ZW, ARIPO patent (GH, GM, KE, LS, MW, SD, SZ, UG, ZW), Eurasian patent (AM, AZ, BY, KG, KZ, MD, RU, TJ, TM), European patent (AT, BE, CH, CY, DE, DK, ES, FI, FR, GB, GR, IE, IT, LU, MC, NL, PT, SE), OAPI patent (BF, BJ, CF, CG, CI, CM, GA, GN, GW, ML, MR, NE, SN, TD, TG).</p> <p>Published <i>With international search report. Before the expiration of the time limit for amending the claims and to be republished in the event of the receipt of amendments.</i></p>	

(54) Title: **BLOOD ANALYTE MONITORING THROUGH SUBCUTANEOUS MEASUREMENT**

(57) Abstract

One embodiment of the invention is a method for obtaining an estimate of an analyte concentration in a first fluid. First, measurements of an analyte concentration in a second fluid are obtained using a sensing device. An analyte concentration estimate in the first fluid is determined from these measurements by minimizing the relation: $f[b] = \chi^2[b] + \lambda \Psi[b]$, where b is a vector representing analyte concentration in the first body fluid, $\chi^2[b]$ is a function representing a fit between the estimates and the measurements, λ is a weighting function, and $\Psi[b]$ is a function indicating smoothness of the analyte concentration estimates in the first fluid. Another embodiment includes a sensing device for obtaining the measurements of analyte concentration in the first fluid and a processor configured and arranged to determine the analyte concentration in the first body fluid according to this method. This method and device can be used, for example, to determine blood glucose concentration from measurements of the glucose concentration in subcutaneous tissue. These measurements may be made using *in vitro* or *in vivo* samples. In some instances, a subcutaneously implanted sensing device, such as electrochemical sensor, is used to make the measurements.

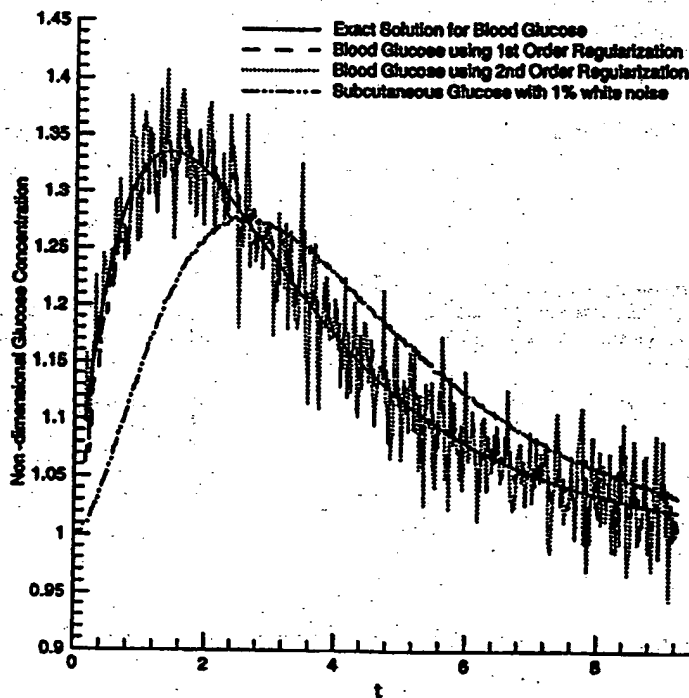

These measurements may be made using *in vitro* or *in vivo* samples. In some instances, a subcutaneously implanted sensing device, such as electrochemical sensor, is used to make the measurements.

FOR THE PURPOSES OF INFORMATION ONLY

Codes used to identify States party to the PCT on the front pages of pamphlets publishing international applications under the PCT.

AL	Albania	ES	Spain	LS	Lesotho	SI	Slovenia
AM	Armenia	FI	Finland	LT	Lithuania	SK	Slovakia
AT	Austria	FR	France	LU	Luxembourg	SN	Senegal
AU	Australia	GA	Gabon	LV	Latvia	SZ	Swaziland
AZ	Azerbaijan	GB	United Kingdom	MC	Monaco	TD	Chad
BA	Bosnia and Herzegovina	GE	Georgia	MD	Republic of Moldova	TG	Togo
BB	Barbados	GH	Ghana	MG	Madagascar	TJ	Tajikistan
BE	Belgium	GN	Guinea	MK	The former Yugoslav Republic of Macedonia	TM	Turkmenistan
BF	Burkina Faso	GR	Greece	ML	Mali	TR	Turkey
BG	Bulgaria	HU	Hungary	MN	Mongolia	TT	Trinidad and Tobago
BJ	Benin	IE	Ireland	MR	Mauritania	UA	Ukraine
BR	Brazil	IL	Israel	MW	Malawi	UG	Uganda
BY	Belarus	IS	Iceland	MX	Mexico	US	United States of America
CA	Canada	IT	Italy	NE	Niger	UZ	Uzbekistan
CF	Central African Republic	JP	Japan	NL	Netherlands	YN	Viet Nam
CG	Congo	KE	Kenya	NO	Norway	YU	Yugoslavia
CH	Switzerland	KG	Kyrgyzstan	NZ	New Zealand	ZW	Zimbabwe
CI	Côte d'Ivoire	KP	Democratic People's Republic of Korea	PL	Poland		
CM	Cameroon	KR	Republic of Korea	PT	Portugal		
CN	China	KZ	Kazakstan	RO	Romania		
CU	Cuba	LC	Saint Lucia	RU	Russian Federation		
CZ	Czech Republic	LI	Liechtenstein	SD	Sudan		
DE	Germany	LK	Sri Lanka	SE	Sweden		
DK	Denmark	LR	Liberia	SG	Singapore		
EE	Estonia						

BLOOD ANALYTE MONITORING THROUGH SUBCUTANEOUS MEASUREMENT

5 The present invention is, in general, directed to devices and methods for the monitoring of the concentration of an analyte, such as glucose, using a subcutaneous sensor. More particularly, the present invention relates to devices and methods for the monitoring of an analyte using a subcutaneous electrochemical sensor to provide information to a patient about the level of the analyte in blood.

10

Background of the Invention

 The monitoring of the level of analytes, such as glucose, lactate or oxygen, in certain individuals is vitally important to their health. High or low levels of these analytes may have detrimental effects. For example, the monitoring of glucose is particularly important to individuals with diabetes, as they must determine when
15 insulin is needed to reduce glucose levels in their bodies or when additional glucose is needed to raise the level of glucose.

 A variety of methods have been used to measure analyte concentrations. For example, colorimetric, electrochemical, and optical methods have been developed for the determination of blood glucose concentration. Implanted electrochemical
20 sensors may be used to periodically or continuously monitor glucose (or other analyte) concentration. Although sensors accurately measure the glucose concentration when inserted directly into the bloodstream, infection may occur at this implantation site.

 A variety of sensors have been developed for implantation in subcutaneous
25 tissue to measure the subcutaneous glucose concentration, which is thought to be well correlated with the blood glucose concentration at steady-state. Subcutaneously implanted glucose sensors, such as miniaturized electrodes "wired" to glucose oxidase, are one technology that hold promise for continuous monitoring of blood glucose levels by diabetic patients. These sensors measure subcutaneous glucose
30 concentrations as glucose diffuses from the blood into the subcutaneous tissue and then to the enzyme electrode surface. At this surface, the glucose is oxidized and the

reaction causes electrons to be transferred to the electrode surface. The resulting current is proportional to the concentration of glucose in the region of implantation.

In many cases, it is important to be able to convert a value from a subcutaneous concentration to a blood concentration. For example, a subcutaneous sensor may be calibrated using blood measurements or a diagnosis or method of treatment may depend on the knowledge of the blood analyte concentration that is obtained using a subcutaneous sensor. However, a lag typically results between the blood and subcutaneous glucose concentrations as the blood glucose level increases or decreases. In addition, the subcutaneous analyte concentrations obtained from sensor measurements may be different from the blood analyte concentration because of the existence of a mass transfer barrier. Thus, there is a need to develop devices and methods that can convert subcutaneous analyte measurements to blood analyte concentrations to ensure accuracy, compatibility, and comparability between measurements made by subcutaneous electrochemical sensors and those made using other conventional blood analysis techniques.

Summary of the Invention

Generally, the present invention relates to methods and devices for determination of analyte concentration in one body fluid using analyte concentration measurements from a second body fluid. In particular, the present invention includes methods and devices for the determination of blood glucose concentration using glucose concentration measurements from subcutaneous fluids.

One embodiment of the invention is a method for obtaining an estimate of an analyte concentration in a first fluid. First, measurements of an analyte concentration in a second fluid are obtained using a sensing device. An analyte concentration estimate in the first body fluid is determined from these measurements by minimizing the relation:

$$f[b] = \chi^2[b] + \lambda\Psi[b],$$

where b is a vector representing analyte concentration in the first fluid, $\chi^2[b]$ is a function representing a fit between the estimates and the measurements, λ is a weighting function, and $\Psi[b]$ is a function indicating smoothness of the analyte concentration estimates in the first body fluid. Another embodiment includes a

sensing device for obtaining the measurements of analyte concentration in the first fluid and a processor configured and arranged to determine the analyte concentration according to this method.

This method and device can be used, for example, to determine blood
5 glucose concentration from measurements of the glucose concentration in subcutaneous tissue. These measurements may be made using *in vitro* or *in vivo* samples. In some instances, a subcutaneously implanted sensing device, such as an electrochemical sensor, is used to make the measurements.

Another embodiment is a method of determining blood analyte concentration
10 including obtaining a subcutaneous analyte concentration from a subcutaneous region using a sensing device and determining a blood analyte concentration from the subcutaneous analyte concentration based on a) mass transfer of the analyte from blood to the subcutaneous region and b) uptake of the analyte by subcutaneous cells in the subcutaneous region. Examples of analytes include glucose, lactate, and
15 oxygen. Yet another embodiment is an analyte measurement device including a processor configured and arranged to determine the analyte concentration according to this method and an optional sensing device, such as an electrochemical sensor, for obtaining the measurements of analyte concentration in the first fluid. In some instances, the electrochemical sensor may be subcutaneously implanted and the
20 analyte measurement device may periodically or continuously monitor glucose.

The above summary of the present invention is not intended to describe each disclosed embodiment or every implementation of the present invention. The Figures and the detailed description which follow more particularly exemplify these embodiments.

25

Brief Description of the Drawings

The invention may be more completely understood in consideration of the following detailed description of various embodiments of the invention in connection with the accompanying drawings, in which:

Figure 1 is a block diagram of one embodiment of a subcutaneous analyte
30 monitor using a subcutaneously implantable analyte sensor, according to the invention;

Figure 2 is a top view of one embodiment of an analyte sensor, according to the invention;

Figure 3A is a cross-sectional view of the analyte sensor of Figure 2;

Figure 3B is a cross-sectional view of another embodiment of an analyte sensor, according to the invention;

Figure 4A is a cross-sectional view of a third embodiment of an analyte sensor, according to the invention;

Figure 4B is a cross-sectional view of a fourth embodiment of an analyte sensor, according to the invention;

Figure 5 is an expanded top view of a tip portion of the analyte sensor of Figure 2;

Figure 6 is a cross-sectional view of a fifth embodiment of an analyte sensor, according to the invention;

Figure 7 is an expanded top view of a tip-portion of the analyte sensor of Figure 6;

Figure 8 is an expanded bottom view of a tip-portion of the analyte sensor of Figure 6;

Figure 9 is a side view of the analyte sensor of Figure 2;

Figure 10 is a top view of the analyte sensor of Figure 6;

Figure 11 is a bottom view of the analyte sensor of Figure 6;

Figure 12 is an expanded side view of one embodiment of a sensor and an insertion device, according to the invention;

Figures 13A, 13B, 13C are cross-sectional views of three embodiments of the insertion device of Figure 12;

Figure 14 is a cross-sectional view of one embodiment of a on-skin sensor control unit, according to the invention;

Figure 15 is a top view of a base of the on-skin sensor control unit of Figure 14;

Figure 16 is a bottom view of a cover of the on-skin sensor control unit of Figure 14;

Figure 17 is a perspective view of the on-skin sensor control unit of Figure 14 on the skin of a patient;

Figure 18A is a block diagram of one embodiment of an on-skin sensor control unit, according to the invention;

Figure 18B is a block diagram of another embodiment of an on-skin sensor control unit, according to the invention;

5 Figures 19A, 19B, 19C, and 19D are cross-sectional views of four embodiments of conductive contacts disposed on an interior surface of a housing of an on-skin sensor control unit, according to the invention;

10 Figures 19E and 19F are cross-sectional views of two embodiments of conductive contacts disposed on an exterior surface of a housing of an on-skin sensor control unit, according to the invention;

 Figures 20A and 20B are schematic diagrams of two embodiments of a current-to-voltage converter for use in an analyte monitoring device, according to the invention;

15 Figure 21 is a block diagram of one embodiment of an open loop modulation system for use in an analyte monitoring device, according to the invention;

 Figure 22 is a block diagram of one embodiment of a receiver/display unit, according to the invention;

 Figure 23 is a front view of one embodiment of a receiver/display unit;

 Figure 24 is a front view of a second embodiment of a receiver/display unit;

20 Figure 25 is a block diagram of one embodiment of a drug delivery system, according to the invention;

 Figure 26 is a perspective view of the internal structure of an insertion gun, according to the invention;

25 Figure 27A is a top view of one embodiment of an on-skin sensor control unit, according to the invention;

 Figure 27B is a top view of one embodiment of a mounting unit of the on-skin sensor control unit of Figure 27A;

 Figure 28A is a top view of another embodiment of an on-skin sensor control unit after insertion of an insertion device and a sensor, according to the invention;

30 Figure 28B is a top view of one embodiment of a mounting unit of the on-skin sensor control unit of Figure 28A;

Figure 28C is a top view of one embodiment of a housing for at least a portion of the electronics of the on-skin sensor control unit of Figure 28A;

Figure 28D is a bottom view of the housing of Figure 28C;

Figure 28E is a top view of the on-skin sensor control unit of Figure 28A
5 with a cover of the housing removed;

Figure 29 is another embodiment of an analyte sensor;

Figure 30 is a graph of experimental data (smooth line) from a rat during an intravenous insulin injection and a prediction using an inverse model with no regularization (oscillating line);

10 Figure 31 is a graph of simulated blood glucose response (solid line) and three models used to simulate subcutaneous glucose response including a) $k_r = 0$, b) $k_r = 1$, $K_m = B_0/3$, and c) $k_r = 1$, $K_m = B_0$;

Figure 32 is a graph of simulated subcutaneous glucose response with white noise (dotted line) and time-correlated noise (solid line) at a noise level of 1 %;

15 Figure 33 is a graph of first- and second-order regularization for a solution of blood glucose concentration based on simulated subcutaneous glucose concentration;

Figure 34 is a graph of error magnification factor versus weighting factor for zeroeth-, first-, and second-order regularization;

20 Figure 35 is a graph of error magnification factor versus weighting factor for zeroeth-, first-, and second-order regularization, varying values of window size and data sampling time;

Figure 36 is a graph of magnification factor versus weighting factor for $k_r = 0$ and $N\Delta t = 1.481$;

25 Figure 37 is a graph of magnification factor versus weighting factor including white noise or time-correlated noise in the simulated subcutaneous glucose concentration;

Figure 38 is a graph of squared model error versus weight factor;

30 Figure 39 is a graph of magnification factor versus weighting factor for a) $k_r = 0$ and b) $k_r = 1$, $K_m = B_0$;

Figure 40 is a graph of glucose concentration illustrating a decline in concentration of glucose after intravenous injection of insulin;

Figure 41 is a graph of estimated glucose concentration of a subcutaneously implanted sensor (dotted line), an intravascularly implanted sensor (solid line), and venous blood glucose concentration (circles) after an i.v. bolus of insulin.

Figure 42 is a graph of average difference (n=7) of subcutaneous glucose estimates relative to actual blood glucose measurements, % difference = 100 X (subcutaneous estimate - blood measurement)/(blood measurement);

Figure 43 is a graph of subcutaneous glucose concentration predicted using a forward model (dotted lines) based on data from a jugular sensor and measured subcutaneous glucose concentration (solid line); and

Figure 44 includes graphs for seven rats comparing blood glucose concentration as determined by a sensor (solid line) and predicted by an inverse model with regularization (dashed line).

While the invention is amenable to various modifications and alternative forms, specifics thereof have been shown by way of example in the drawings and will be described in detail. It should be understood, however, that the intention is not to limit the invention to the particular embodiments described. On the contrary, the intention is to cover all modifications, equivalents, and alternatives falling within the spirit and scope of the invention as defined by the appended claims.

Detailed Description of the Invention

The present invention is applicable to a method and analyte measurement systems for determining analyte concentration in one body fluid (e.g., blood) from measured analyte concentrations in another body fluid (e.g., subcutaneous fluid). Suitable analyte measurement systems typically include a sensing device and a processor. The analyte measurement system may be configured and arranged to provide readings as required by a user when, for example, the user provides a sample to the device. In other embodiments, the analyte measurement system may be configured and arranged to be permanently or temporarily attached to an animal (such as a human) to provide periodic or continuous monitoring.

For example, the analyte measurement system can be an analyte monitoring system using a subcutaneously implantable electrochemical sensor for the *in vivo* determination of a blood concentration of an analyte, such as, for example, glucose,

lactate, or oxygen. The sensor can be, for example, subcutaneously implanted in a patient for the continuous or periodic monitoring of the analyte. The analyte monitoring system typically includes a subcutaneously implantable sensor and a processor coupled to the sensor to determine the blood analyte concentration from the sensor measurements.

A variety of suitable sensing devices are available. A suitable sensing device is configured and arranged to provide some signal, for example, an optical (e.g., color change, absorption, transmission, or fluorescence) or electrical signal (e.g., a change in current, potential, capacitance, or conductivity) that is related to a level of the analyte in the sample. Suitable sensing devices include electrochemical sensing devices, optical sensing devices, and colorimetric sensing devices. A sample of a body fluid may be provided, conveyed, or transported to the sensing device for *in vitro* determination of the analyte concentration in the body fluid. In other embodiments, the sensing device (e.g., an electrochemical sensor) may be implanted to provide *in vivo* determination of analyte concentration. In yet other embodiments, the sensing device (e.g., an optical device) may be directed toward the animal or a sample from the animal and the analyte concentration determined by, for example, interaction of light with the tissue and/or body fluid of the animal.

The determination of blood glucose concentration from subcutaneous glucose measurements is used herein as an illustration. It will be understood that other analytes may also be measured. It will also be understood that the devices and methods described herein can be applied to the determination of analyte concentration in body fluids, other than blood, based on measurement of analyte concentration in a second body fluid.

The following definitions are provided for terms used herein:

A "counter electrode" refers to an electrode paired with the working electrode, through which passes a current equal in magnitude and opposite in sign to the current passing through the working electrode. In the context of the invention, the term "counter electrode" is meant to include counter electrodes which also function as reference electrodes (i.e., a counter/reference electrode).

An "electrochemical sensor" is a device configured to detect the presence and/or measure the level of an analyte in a sample via electrochemical oxidation and

reduction reactions on the sensor. These reactions are transduced to an electrical signal that can be correlated to an amount, concentration, or level of an analyte in the sample.

“Electrolysis” is the electrooxidation or electroreduction of a compound either directly at an electrode or via one or more electron transfer agents.

A compound is “immobilized” on a surface when it is entrapped on or chemically bound to the surface.

A “non-leachable” or “non-releasable” compound or a compound that is “non-leachably disposed” is meant to define a compound that is affixed on the sensor such that it does not substantially diffuse away from the working surface of the working electrode for the period in which the sensor is used (e.g., the period in which the sensor is implanted in a patient or measuring a sample).

Components are “immobilized” within a sensor, for example, when the components are covalently, ionically, or coordinatively bound to constituents of the sensor and/or are entrapped in a polymeric or sol-gel matrix or membrane which precludes mobility.

An “electron transfer agent” is a compound that carries electrons between the analyte and the working electrode, either directly, or in cooperation with other electron transfer agents. One example of an electron transfer agent is a redox mediator.

A “working electrode” is an electrode at which the analyte (or a second compound whose level depends on the level of the analyte) is electrooxidized or electroreduced with or without the agency of an electron transfer agent.

A “working surface” is that portion of the working electrode which is coated with or is accessible to the electron transfer agent and configured for exposure to an analyte-containing fluid.

A “sensing layer” is a component of the sensor which includes constituents that facilitate the electrolysis of the analyte. The sensing layer may include constituents such as an electron transfer agent, a catalyst which catalyzes a reaction of the analyte to produce a response at the electrode, or both. In some embodiments of the sensor, the sensing layer is non-leachably disposed in proximity to or on the working electrode.

A "non-corroding" conductive material includes non-metallic materials, such as carbon and conductive polymers.

Sensing Devices

5 The methods and devices of the invention are illustrated using electrochemical sensors. However, it will be understood that a variety of sensing devices, including electrochemical, optical, and colorimetric sensing devices may be used. Moreover, the methods and devices are illustrated using implantable sensing devices, however, it will be understood that other non-implantable sensing devices
10 can be used.

 A variety of subcutaneously implantable sensors are available for use. Examples of such sensors and analyte measurement systems incorporating the sensors are described in U.S. Patent No. 5,593,852 and U.S. Patent Applications Serial Nos. 09/034,372, 09/034,422, and 09/070,677, all of which are incorporated
15 herein by reference. An example of one sensor is illustrated in Figure 29 and described in detail in U.S. Patent No. 5,593,852. This sensor includes a metal or carbon working electrode 2 with an electrically insulating material 4 wrapped around the electrode. A recess 6 is provided by, for example, removing a portion of the working electrode 2. This leaves an exposed surface 18 of the working electrode.

20 A sensing layer 8 is formed over the exposed surface 18. The sensing layer 8 may include a redox mediator and/or a redox enzyme. In at least some embodiments, the redox mediator and/or redox enzyme are non-leachably disposed in the sensor, as described in U.S. Patent No. 5,593,852. Exemplary redox mediators and redox enzymes are described in U.S. Patent No. 5,593,852 and U.S.
25 Patent Applications Serial Nos. 09/034,372, 09/034,422, and 09/070,677.

 An optional glucose diffusion limiting layer 10, an optional interferent eliminating layer 12, and an optional biocompatible layer 14 can be formed in the recess 6. These layers are described in more detail in U.S. Patent No. 5,593,852.

30 Another Sensor and an Analyte Monitoring System

 The analyte monitoring systems of the present invention can be utilized under a variety of conditions. The particular configuration of a sensor and other

units used in the analyte monitoring system may depend on the use for which the analyte monitoring system is intended and the conditions under which the analyte monitoring system will operate. One embodiment of the analyte monitoring system includes a sensor configured for implantation into a patient or user. For example, 5 implantation of the sensor may be made in the arterial or venous systems for direct testing of analyte levels in blood. Alternatively, a sensor may be implanted in the interstitial tissue for determining the analyte level in interstitial fluid. This level may be correlated and/or converted to analyte levels in blood or other fluids. The site and depth of implantation may affect the particular shape, components, and 10 configuration of the sensor. Subcutaneous implantation may be preferred, in some cases, to limit the depth of implantation of the sensor. Sensors may also be implanted in other regions of the body to determine analyte levels in other fluids. Examples of suitable sensor for use in the analyte monitoring systems of the invention are described in U.S. Patent Application, Serial No. 09/034,372, 15 incorporated herein by reference.

One embodiment of the analyte monitoring system 40 for use with an implantable sensor 42, and particularly for use with a subcutaneously implantable sensor, is illustrated in block diagram form in Figure 1. The analyte monitoring system 40 includes, at minimum, a sensor 42, a portion of which is configured for 20 implantation (e.g., subcutaneous, venous, or arterial implantation) into a patient, and a sensor control unit 44. The sensor 42 is coupled to the sensor control unit 44 which is typically attached to the skin of a patient. The sensor control unit 44 operates the sensor 42, including, for example, providing a voltage across the electrodes of the sensor 42 and collecting signals from the sensor 42. The sensor 25 control unit 44 may evaluate the signals from the sensor 42 and/or transmit the signals to one or more optional receiver/display units 46, 48 for evaluation. The sensor control unit 44 and/or the receiver/display units 46, 48 may display or otherwise communicate the current level of the analyte. Furthermore, the sensor control unit 44 and/or the receiver/display units 46, 48 may indicate to the patient, 30 via, for example, an audible, visual, or other sensory-stimulating alarm, when the level of the analyte is at or near a threshold level. In some embodiments, a electrical shock can be delivered to the patient as a warning through one of the electrodes or

the optional temperature probe of the sensor. For example, if glucose is monitored then an alarm may be used to alert the patient to a hypoglycemic or hyperglycemic glucose level and/or to impending hypoglycemia or hyperglycemia.

5 The Sensor

A sensor 42 includes at least one working electrode 58 formed on a substrate 50, as shown in Figure 2. The sensor 42 may also include at least one counter electrode 60 (or counter/reference electrode) and/or at least one reference electrode 62 (see Figure 8). The counter electrode 60 and/or reference electrode 62 may be
10 formed on the substrate 50 or may be separate units. For example, the counter electrode and/or reference electrode may be formed on a second substrate which is also implanted in the patient or, for some embodiments of the implantable sensors, the counter electrode and/or reference electrode may be placed on the skin of the patient with the working electrode or electrodes being implanted into the patient.
15 The use of an on-the-skin counter and/or reference electrode with an implantable working electrode is described in U.S. Patent No. 5,593, 852, incorporated herein by reference.

The working electrode or electrodes 58 are formed using conductive traces 52 disposed on the substrate 50. The counter electrode 60 and/or reference electrode
20 62, as well as other optional portions of the sensor 42, such as a temperature probe 66 (see Figure 8), may also be formed using conductive traces 52 disposed on the substrate 50. These conductive traces 52 may be formed over a smooth surface of the substrate 50 or within channels 54 formed by, for example, embossing, indenting or otherwise creating a depression in the substrate 50.

25 A sensing layer 64 (see Figures 3A and 3B) is often formed proximate to or on at least one of the working electrodes 58 to facilitate the electrochemical detection of the analyte and the determination of its level in the sample fluid, particularly if the analyte can not be electrolyzed at a desired rate and/or with a desired specificity on a bare electrode. The sensing layer 64 may include an electron
30 transfer agent to transfer electrons directly or indirectly between the analyte and the working electrode 58. The sensing layer 64 may also contain a catalyst to catalyze a reaction of the analyte. The components of the sensing layer may be in a fluid or gel

that is proximate to or in contact with the working electrode 58. Alternatively, the components of the sensing layer 64 may be disposed in a polymeric or sol-gel matrix that is proximate to or on the working electrode 58. Preferably, the components of the sensing layer 64 are non-leachably disposed within the sensor 42. More preferably, the components of the sensor 42 are immobilized within the sensor 42.

In addition to the electrodes 58, 60, 62 and the sensing layer 64, the sensor 42 may also include a temperature probe 66 (see Figures 6 and 8), a mass transport limiting layer 74 (see Figure 9), a biocompatible layer 75 (see Figure 9), and/or other optional components, as described below. Each of these items enhances the functioning of and/or results from the sensor 42, as discussed below.

The Substrate

The substrate 50 may be formed using a variety of non-conducting materials, including, for example, polymeric or plastic materials and ceramic materials. Suitable materials for a particular sensor 42 may be determined, at least in part, based on the desired use of the sensor 42 and properties of the materials.

In some embodiments, the substrate is flexible. For example, if the sensor 42 is configured for implantation into a patient, then the sensor 42 may be made flexible (although rigid sensors may also be used for implantable sensors) to reduce pain to the patient and damage to the tissue caused by the implantation of and/or the wearing of the sensor 42. A flexible substrate 50 often increases the patient's comfort and allows a wider range of activities. Suitable materials for a flexible substrate 50 include, for example, non-conducting plastic or polymeric materials and other non-conducting, flexible, deformable materials. Examples of useful plastic or polymeric materials include thermoplastics such as polycarbonates, polyesters (e.g., Mylar™ and polyethylene terephthalate (PET)), polyvinyl chloride (PVC), polyurethanes, polyethers, polyamides, polyimides, or copolymers of these thermoplastics, such as PETG (glycol-modified polyethylene terephthalate).

In other embodiments, the sensors 42 are made using a relatively rigid substrate 50 to, for example, provide structural support against bending or breaking. Examples of rigid materials that may be used as the substrate 50 include poorly conducting ceramics, such as aluminum oxide and silicon dioxide. One advantage

of an implantable sensor 42 having a rigid substrate is that the sensor 42 may have a sharp point and/or a sharp edge to aid in implantation of a sensor 42 without an additional insertion device.

It will be appreciated that for many sensors 42 and sensor applications, both
5 rigid and flexible sensors will operate adequately. The flexibility of the sensor 42 may also be controlled and varied along a continuum by changing, for example, the composition and/or thickness of the substrate 50.

In addition to considerations regarding flexibility, it is often desirable that implantable sensors 42 should have a substrate 50 which is non-toxic. Preferably,
10 the substrate 50 is approved by one or more appropriate governmental agencies or private groups for *in vivo* use.

The sensor 42 may include optional features to facilitate insertion of an implantable sensor 42, as shown in Figure 12. For example, the sensor 42 may be pointed at the tip 123 to ease insertion. In addition, the sensor 42 may include a barb
15 125 which assists in anchoring the sensor 42 within the tissue of the patient during operation of the sensor 42. However, the barb 125 is typically small enough that little damage is caused to the subcutaneous tissue when the sensor 42 is removed for replacement.

Although the substrate 50 in at least some embodiments has uniform
20 dimensions along the entire length of the sensor 42, in other embodiments, the substrate 50 has a distal end 67 and a proximal end 65 with different widths 53, 55, respectively, as illustrated in Figure 2. In these embodiments, the distal end 67 of the substrate 50 may have a relatively narrow width 53. For sensors 42 which are implantable into the subcutaneous tissue or another portion of a patient's body, the
25 narrow width 53 of the distal end 67 of the substrate 50 may facilitate the implantation of the sensor 42. Often, the narrower the width of the sensor 42, the less pain the patient will feel during implantation of the sensor and afterwards.

For subcutaneously implantable sensors 42 which are designed for continuous or periodic monitoring of the analyte during normal activities of the
30 patient, a distal end 67 of the sensor 42 which is to be implanted into the patient has a width 53 of 2mm or less, preferably 1mm or less, and more preferably 0.5mm or less. If the sensor 42 does not have regions of different widths, then the sensor 42

will typically have an overall width of, for example, 2 mm, 1.5 mm, 1 mm, 0.5 mm, 0.25 mm, or less. However, wider or narrower sensors may be used. In particular, wider implantable sensors may be used for insertion into veins or arteries or when the movement of the patient is limited, for example, when the patient is confined in
5 bed or in a hospital.

Returning to Figure 2, the proximal end 65 of the sensor 42 may have a width 55 larger than the distal end 67 to facilitate the connection between contact pads 49 of the electrodes and contacts on a control unit. The wider the sensor 42 at this point, the larger the contact pads 49 can be made. This may reduce the precision
10 needed to properly connect the sensor 42 to contacts on the control unit (e.g., sensor control unit 44 of Figure 1). However, the maximum width of the sensor 42 may be constrained so that the sensor 42 remains small for the convenience and comfort of the patient and/or to fit the desired size of the analyte monitor. For example, the proximal end 65 of a subcutaneously implantable sensor 42, such as the sensor 42
15 illustrated in Figure 1, may have a width 55 ranging from 0.5mm to 15mm, preferably from 1mm to 10mm, and more preferably from 3mm to 7mm. However, wider or narrower sensors may be used in this and other *in vivo* applications.

The thickness of the substrate 50 may be determined by the mechanical properties of the substrate material (e.g., the strength, modulus, and/or flexibility of
20 the material), the desired use of the sensor 42 including stresses on the substrate 50 arising from that use, as well as the depth of any channels or indentations formed in the substrate 50, as discussed below. Typically, the substrate 50 of a subcutaneously implantable sensor 42 for continuous or periodic monitoring of the level of an analyte while the patient engages in normal activities has a thickness of 50 to 500
25 μm and preferably 100 to 300 μm . However, thicker and thinner substrates 50 may be used, particularly in other types of *in vivo* sensors 42.

The length of the sensor 42 may have a wide range of values depending on a variety of factors. Factors which influence the length of an implantable sensor 42 may include the depth of implantation into the patient and the ability of the patient to
30 manipulate a small flexible sensor 42 and make connections between the sensor 42 and the sensor control unit 44. A subcutaneously implantable sensor 42 for the analyte monitor illustrated in Figure 1 may have a length ranging from 0.3 to 5 cm,

however, longer or shorter sensors may be used. The length of the narrow portion of the sensor 42 (e.g., the portion which is subcutaneously inserted into the patient), if the sensor 42 has narrow and wide portions, is typically about 0.25 to 2 cm in length. However, longer and shorter portions may be used. All or only a part of this narrow
5 portion may be subcutaneously implanted into the patient. The lengths of other implantable sensors 42 will vary depending, at least in part, on the portion of the patient into which the sensor 42 is to be implanted or inserted.

Conductive Traces

10 At least one conductive trace 52 is formed on the substrate for use in constructing a working electrode 58. In addition, other conductive traces 52 may be formed on the substrate 50 for use as electrodes (e.g., additional working electrodes, as well as counter, counter/reference, and/or reference electrodes) and other
15 components, such as a temperature probe. The conductive traces 52 may extend most of the distance along a length 57 of the sensor 50, as illustrated in Figure 2, although this is not necessary. The placement of the conductive traces 52 may depend on the particular configuration of the analyte monitoring system (e.g., the placement of control unit contacts and/or the sample chamber in relation to the
20 sensor 42). For implantable sensors, particularly subcutaneously implantable sensors, the conductive traces typically extend close to the tip of the sensor 42 to minimize the amount of the sensor that must be implanted.

The conductive traces 52 may be formed on the substrate 50 by a variety of techniques, including, for example, photolithography, screen printing, or other
25 impact or non-impact printing techniques. The conductive traces 52 may also be formed by carbonizing conductive traces 52 in an organic (e.g., polymeric or plastic) substrate 50 using a laser. A description of some exemplary methods for forming the sensor 42 is provided in U.S. Patent Application Serial No. 09/034,422, incorporated herein by reference.

Another method for disposing the conductive traces 52 on the substrate 50
30 includes the formation of recessed channels 54 in one or more surfaces of the substrate 50 and the subsequent filling of these recessed channels 54 with a conductive material 56, as shown in Figure 3A. The recessed channels 54 may be

formed by indenting, embossing, or otherwise creating a depression in the surface of the substrate 50. Exemplary methods for forming channels and electrodes in a surface of a substrate can be found in U.S. Patent Application Serial No. 09/034,422. The depth of the channels is typically related to the thickness of the substrate 50. In one embodiment, the channels have depths in the range of about 12.5 to 75 μm (0.5 to 3 mils), and preferably about 25 to 50 μm (1 to 2 mils).

The conductive traces are typically formed using a conductive material 56 such as carbon (e.g., graphite), a conductive polymer, a metal or alloy (e.g., gold or gold alloy), or a metallic compound (e.g., ruthenium dioxide or titanium dioxide). The formation of films of carbon, conductive polymer, metal, alloy, or metallic compound are well-known and include, for example, chemical vapor deposition (CVD), physical vapor deposition, sputtering, reactive sputtering, printing, coating, and painting. The conductive material 56 which fills the channels 54 is often formed using a precursor material, such as a conductive ink or paste. In these embodiments, the conductive material 56 is deposited on the substrate 50 using methods such as coating, painting, or applying the material using a spreading instrument, such as a coating blade. Excess conductive material between the channels 54 is then removed by, for example, running a blade along the substrate surface.

In one embodiment, the conductive material 56 is a part of a precursor material, such as a conductive ink, obtainable, for example, from Ercon, Inc. (Wareham, MA), Metech, Inc. (Elverson, PA), E.I. du Pont de Nemours and Co. (Wilmington, DE), Emca-Remex Products (Montgomeryville, PA), or MCA Services (Melbourn, Great Britain). The conductive ink is typically applied as a semiliquid or paste which contains particles of the carbon, metal, alloy, or metallic compound and a solvent or dispersant. After application of the conductive ink on the substrate 50 (e.g., in the channels 54), the solvent or dispersant evaporates to leave behind a solid mass of conductive material 56.

In addition to the particles of carbon, metal, alloy, or metallic compound, the conductive ink may also contain a binder. The binder may optionally be cured to further bind the conductive material 56 within the channel 54 and/or on the substrate 50. Curing the binder increases the conductivity of the conductive material 56. However, this is typically not necessary as the currents carried by the conductive

material 56 within the conductive traces 52 are often relatively low (usually less than 1 μ A and often less than 100 nA). Typical binders include, for example, polyurethane resins, cellulose derivatives, elastomers, and highly fluorinated polymers. Examples of elastomers include silicones, polymeric dienes, and acrylonitrile-butadiene-styrene (ABS) resins. One example of a fluorinated polymer binder is Teflon[®] (DuPont, Wilmington, DE). These binders are cured using, for example, heat or light, including ultraviolet (UV) light. The appropriate curing method typically depends on the particular binder which is used.

Often, when a liquid or semiliquid precursor of the conductive material 56 (e.g., a conductive ink) is deposited in the channel 54, the precursor fills the channel 54. However, when the solvent or dispersant evaporates, the conductive material 56 which remains may lose volume such that the conductive material 56 may or may not continue to fill the channel 54. Preferred conductive materials 56 do not pull away from the substrate 50 as they lose volume, but rather decrease in height within the channel 54. These conductive materials 56 typically adhere well to the substrate 50 and therefore do not pull away from the substrate 50 during evaporation of the solvent or dispersant. Other suitable conductive materials 56 either adhere to at least a portion of the substrate 50 and/or contain another additive, such as a binder, which adheres the conductive material 56 to the substrate 50. Preferably, the conductive material 56 in the channels 54 is non-leachable, and more preferably immobilized on the substrate 50. In some embodiments, the conductive material 56 may be formed by multiple applications of a liquid or semiliquid precursor interspersed with removal of the solvent or dispersant.

In another embodiment, the channels 54 are formed using a laser. The laser carbonizes the polymer or plastic material. The carbon formed in this process is used as the conductive material 56. Additional conductive material 56, such as a conductive carbon ink, may be used to supplement the carbon formed by the laser.

In a further embodiment, the conductive traces 52 are formed by pad printing techniques. For example, a film of conductive material is formed either as a continuous film or as a coating layer deposited on a carrier film. This film of conductive material is brought between a print head and the substrate 50. A pattern on the surface of the substrate 50 is made using the print head according to a desired

pattern of conductive traces 52. The conductive material is transferred by pressure and/or heat from the film of conductive material to the substrate 50. This technique often produces channels (e.g., depressions caused by the print head) in the substrate 50. Alternatively, the conductive material is deposited on the surface of the substrate 50 without forming substantial depressions.

In other embodiments, the conductive traces 52 are formed by non-impact printing techniques. Such techniques include electrophotography and magnetography. In these processes, an image of the conductive traces 52 is electrically or magnetically formed on a drum. A laser or LED may be used to electrically form an image. A magnetic recording head may be used to magnetically form an image. A toner material (e.g., a conductive material, such as a conductive ink) is then attracted to portions of the drum according to the image. The toner material is then applied to the substrate by contact between the drum and the substrate. For example, the substrate may be rolled over the drum. The toner material may then be dried and/or a binder in the toner material may be cured to adhere the toner material to the substrate.

Another non-impact printing technique includes ejecting droplets of conductive material onto the substrate in a desired pattern. Examples of this technique include ink jet printing and piezo jet printing. An image is sent to the printer which then ejects the conductive material (e.g., a conductive ink) according to the pattern. The printer may provide a continuous stream of conductive material or the printer may eject the conductive material in discrete amounts at the desired points.

Yet another non-impact printing embodiment of forming the conductive traces includes an ionographic process. In this process, a curable, liquid precursor, such as a photopolymerizable acrylic resin (e.g., Solimer 7501 from Cubital, Bad Kreuznach, Germany) is deposited over a surface of a substrate 50. A photomask having a positive or negative image of the conductive traces 52 is then used to cure the liquid precursor. Light (e.g., visible or ultraviolet light) is directed through the photomask to cure the liquid precursor and form a solid layer over the substrate according to the image on the photomask. Uncured liquid precursor is

removed leaving behind channels 54 in the solid layer. These channels 54 can then be filled with conductive material 56 to form conductive traces 52.

Conductive traces 52 (and channels 54, if used) can be formed with relatively narrow widths, for example, in the range of 25 to 250 μm , and including widths of, for example, 250 μm , 150 μm , 100 μm , 75 μm , 50 μm , 25 μm or less by the methods described above. In embodiments with two or more conductive traces 52 on the same side of the substrate 50, the conductive traces 52 are separated by distances sufficient to prevent conduction between the conductive traces 52. The edge-to-edge distance between the conductive traces is preferably in the range of 25 to 250 μm and may be, for example, 150 μm , 100 μm , 75 μm , 50 μm , or less. The density of the conductive traces 52 on the substrate 50 is preferably in the range of about 150 to 700 $\mu\text{m}/\text{trace}$ and may be as small as 667 $\mu\text{m}/\text{trace}$ or less, 333 $\mu\text{m}/\text{trace}$ or less, or even 167 $\mu\text{m}/\text{trace}$ or less.

The working electrode 58 and the counter electrode 60 (if a separate reference electrode is used) are often made using a conductive material 56, such as carbon. Suitable carbon conductive inks are available from Ercon, Inc. (Wareham, MA), Metech, Inc. (Elverson, PA), E.I. du Pont de Nemours and Co. (Wilmington, DE), Emca-Remex Products (Montgomeryville, PA), or MCA Services (Melbourn, Great Britain). Typically, the working surface 51 of the working electrode 58 is at least a portion of the conductive trace 52 that is in contact with the analyte-containing fluid (e.g., implanted in the patient).

The reference electrode 62 and/or counter/reference electrode are typically formed using conductive material 56 that is a suitable reference material, for example silver/silver chloride or a non-leachable redox couple bound to a conductive material, for example, a carbon-bound redox couple. Suitable silver/silver chloride conductive inks are available from Ercon, Inc. (Wareham, MA); Metech, Inc. (Elverson, PA), E.I. du Pont de Nemours and Co. (Wilmington, DE), Emca-Remex Products (Montgomeryville, PA), or MCA Services (Melbourn, Great Britain). Silver/silver chloride electrodes illustrate a type of reference electrode that involves the reaction of a metal electrode with a constituent of the sample or body fluid, in this case, Cl^- .

Suitable redox couples for binding to the conductive material of the reference electrode include, for example, redox polymers (e.g., polymers having multiple redox centers.) It is preferred that the reference electrode surface be non-corroding so that an erroneous potential is not measured. Preferred conductive materials include less corrosive metals, such as gold and palladium. Most preferred are non-corrosive materials including non-metallic conductors, such as carbon and conducting polymers. A redox polymer can be adsorbed on or covalently bound to the conductive material of the reference electrode, such as a carbon surface of a conductive trace 52. Non-polymeric redox couples can be similarly bound to carbon or gold surfaces.

A variety of methods may be used to immobilize a redox polymer on an electrode surface. One method is adsorptive immobilization. This method is particularly useful for redox polymers with relatively high molecular weights. The molecular weight of a polymer may be increased, for example, by cross-linking.

Another method for immobilizing the redox polymer includes the functionalization of the electrode surface and then the chemical bonding, often covalently, of the redox polymer to the functional groups on the electrode surface. One example of this type of immobilization begins with a poly(4-vinylpyridine). The polymer's pyridine rings are, in part, complexed with a reducible/oxidizable species, such as $[\text{Os}(\text{bpy})_2\text{Cl}]^{+2}$ where bpy is 2,2'-bipyridine. Part of the pyridine rings are quaternized by reaction with 2-bromoethylamine. The polymer is then crosslinked, for example, using a diepoxide, such as polyethylene glycol diglycidyl ether.

Carbon surfaces can be modified for attachment of a redox species or polymer, for example, by electroreduction of a diazonium salt. As an illustration, reduction of a diazonium salt formed upon diazotization of p-aminobenzoic acid modifies a carbon surface with phenylcarboxylic acid functional groups. These functional groups can then be activated by a carbodiimide, such as 1-ethyl-3-(3-dimethylaminopropyl)-carbodiimide hydrochloride. The activated functional groups are then bound with a amine-functionalized redox couple, such as the quaternized osmium-containing redox polymer described above or 2-aminoethylferrocene, to form the redox couple.

Similarly, gold can be functionalized by an amine, such as cystamine. A redox couple such as $[\text{Os}(\text{bpy})_2(\text{pyridine-4-carboxylate})\text{Cl}]^{0/+}$ is activated by 1-ethyl-3-(3-dimethylaminopropyl)-carbodiimide hydrochloride to form a reactive O-acylisourea which reacts with the gold-bound amine to form an amide.

5 In one embodiment, in addition to using the conductive traces 52 as electrodes or probe leads, two or more of the conductive traces 52 on the substrate 50 are used to give the patient a mild electrical shock when, for example, the analyte level exceeds a threshold level. This shock may act as a warning or alarm to the patient to initiate some action to restore the appropriate level of the analyte.

10 The mild electrical shock is produced by applying a potential between any two conductive traces 52 that are not otherwise connected by a conductive path. For example, two of the electrodes 58, 60, 62 or one electrode 58, 60, 62 and the temperature probe 66 may be used to provide the mild shock. Preferably, the working electrode 58 and the reference electrode 62 are not used for this purpose as
15 this may cause some damage to the chemical components on or proximate to the particular electrode (e.g., the sensing layer on the working electrode or the redox couple on the reference electrode).

The current used to produce the mild shock is typically 0.1 to 1 mA. Higher or lower currents may be used, although care should be taken to avoid harm to the
20 patient. The potential between the conductive traces is typically 1 to 10 volts. However, higher or lower voltages may be used depending, for example, on the resistance of the conductive traces 52, the distance between the conductive traces 52 and the desired amount of current. When the mild shock is delivered, potentials at the working electrode 58 and across the temperature probe 66 may be removed to
25 prevent harm to those components caused by unwanted conduction between the working electrode 58 (and/or temperature probe 66, if used) and the conductive traces 52 which provide the mild shock.

Contact Pads

30 Typically, each of the conductive traces 52 includes a contact pad 49. The contact pad 49 may simply be a portion of the conductive trace 52 that is indistinguishable from the rest of the trace 52 except that the contact pad 49 is

brought into contact with the conductive contacts of a control unit (e.g., the sensor control unit 44 of Figure 1). More commonly, however, the contact pad 49 is a region of the conductive trace 52 that has a larger width than other regions of the trace 52 to facilitate a connection with the contacts on the control unit. By making
5 the contact pads 49 relatively large as compared with the width of the conductive traces 52, the need for precise registration between the contact pads 49 and the contacts on the control unit is less critical than with small contact pads.

The contact pads 49 are typically made using the same material as the conductive material 56 of the conductive traces 52. However, this is not necessary.
10 Although metal, alloys, and metallic compounds may be used to form the contact pads 49, in some embodiments, it is desirable to make the contact pads 49 from a carbon or other non-metallic material, such as a conducting polymer. In contrast to metal or alloy contact pads, carbon and other non-metallic contact pads are not easily corroded if the contact pads 49 are in a wet, moist, or humid environment.
15 Metals and alloys may corrode under these conditions, particularly if the contact pads 49 and contacts of the control unit are made using different metals or alloys. However, carbon and non-metallic contact pads 49 do not significantly corrode, even if the contacts of the control device are metal or alloy.

One embodiment of the invention includes a sensor 42 having contact pads
20 49 and a control unit 44 having conductive contacts (not shown). During operation of the sensor 42, the contact pads 49 and conductive contacts are in contact with each other. In this embodiment, either the contact pads 49 or the conductive contacts are made using a non-corroding, conductive material. Such materials include, for example, carbon and conducting polymers. Preferred non-corroding
25 materials include graphite and vitreous carbon. The opposing contact pad or conductive contact is made using carbon, a conducting polymer, a metal, such as gold, palladium, or platinum group metal, or a metallic compound, such as ruthenium dioxide. This configuration of contact pads and conductive contacts typically reduces corrosion. Preferably, when the sensor is placed in a 3 mM, and
30 more preferably, in a 100 mM, NaCl solution, the signal arising due to the corrosion of the contact pads and/or conductive contacts is less than 3% of the signal generated by the sensor when exposed to concentration of analyte in the normal physiological

range. For at least some subcutaneous glucose sensors, the current generated by analyte in a normal physiological range ranges from 3 to 500 nA.

Each of the electrodes 58, 60, 62, as well as the two probe leads 68, 70 of the temperature probe 66 (described below), are connected to contact pads 49 as shown in Figures 10 and 11. In one embodiment (not shown), the contact pads 49 are on the same side of the substrate 50 as the respective electrodes or temperature probe leads to which the contact pads 49 are attached.

In other embodiments, the conductive traces 52 on at least one side are connected through vias in the substrate to contact pads 49a on the opposite surface of the substrate 50, as shown in Figures 10 and 11. An advantage of this configuration is that contact between the contacts on the control unit and each of the electrodes 58, 60, 62 and the probe leads 68,70 of the temperature probe 66 can be made from a single side of the substrate 50.

In yet other embodiments (not shown), vias through the substrate are used to provide contact pads on both sides of the substrate 50 for each conductive trace 52. The vias connecting the conductive traces 52 with the contact pads 49a can be formed by making holes through the substrate 50 at the appropriate points and then filling the holes with conductive material 56.

20 Exemplary Electrode Configurations

A number of exemplary electrode configurations are described below, however, it will be understood that other configurations may also be used. In one embodiment, illustrated in Figure 3A, the sensor 42 includes two working electrodes 58a, 58b and one counter electrode 60, which also functions as a reference electrode. In another embodiment, the sensor includes one working electrode 58a, one counter electrode 60, and one reference electrode 62, as shown in Figure 3B. Each of these embodiments is illustrated with all of the electrodes formed on the same side of the substrate 50.

Alternatively, one or more of the electrodes may be formed on an opposing side of the substrate 50. This may be convenient if the electrodes are formed using two different types of conductive material 56 (e.g., carbon and silver/silver chloride). Then, at least in some embodiments, only one type of conductive material 56 needs

to be applied to each side of the substrate 50, thereby reducing the number of steps in the manufacturing process and/or easing the registration constraints in the process. For example, if the working electrode 58 is formed using a carbon-based conductive material 56 and the reference or counter/reference electrode is formed using a silver/silver chloride conductive material 56, then the working electrode and reference or counter/reference electrode may be formed on opposing sides of the substrate 50 for ease of manufacture.

In another embodiment, two working electrodes 58 and one counter electrode 60 are formed on one side of the substrate 50 and one reference electrode 62 and a temperature probe 66 are formed on an opposing side of the substrate 50, as illustrated in Figure 6. The opposing sides of the tip of this embodiment of the sensor 42 are illustrated in Figures 7 and 8.

Sensing Layer

Some analytes, such as oxygen, can be directly electrooxidized or electroreduced on the working electrode 58. Other analytes, such as glucose and lactate, require the presence of at least one electron transfer agent and/or at least one catalyst to facilitate the electrooxidation or electroreduction of the analyte. Catalysts may also be used for those analyte, such as oxygen, that can be directly electrooxidized or electroreduced on the working electrode 58. For these analytes, each working electrode 58 has a sensing layer 64 formed proximate to or on a working surface of the working electrode 58. Typically, the sensing layer 64 is formed near or on only a small portion of the working electrode 58, often near a tip of the sensor 42. This limits the amount of material needed to form the sensor 42 and places the sensing layer 64 in the best position for contact with the analyte-containing fluid (e.g., a body fluid, sample fluid, or carrier fluid).

The sensing layer 64 includes one or more components designed to facilitate the electrolysis of the analyte. The sensing layer 64 may include, for example, a catalyst to catalyze a reaction of the analyte and produce a response at the working electrode 58, an electron transfer agent to indirectly or directly transfer electrons between the analyte and the working electrode 58, or both.

The sensing layer 64 may be formed as a solid composition of the desired components (e.g., an electron transfer agent and/or a catalyst). These components are preferably non-leachable from the sensor 42 and more preferably are immobilized on the sensor 42. For example, the components may be immobilized on a working electrode 58. Alternatively, the components of the sensing layer 64 may be immobilized within or between one or more membranes or films disposed over the working electrode 58 or the components may be immobilized in a polymeric or sol-gel matrix. Examples of immobilized sensing layers are described in U.S. Patents Nos. 5,262,035, 5,264,104, 5,264,105, 5,320,725, 5,593,852, and 5,665,222, U.S. Patent Application No. 08/540,789, and PCT Patent Application No. US98/02403 entitled "Soybean Peroxidase Electrochemical Sensor", filed on February 11, 1998, Attorney Docket No. M&G 12008.8WOI2, incorporated herein by reference.

In some embodiments, one or more of the components of the sensing layer 64 may be solvated, dispersed, or suspended in a fluid within the sensing layer 64, instead of forming a solid composition. The fluid may be provided with the sensor 42 or may be absorbed by the sensor 42 from the analyte-containing fluid. Preferably, the components which are solvated, dispersed, or suspended in this type of sensing layer 64 are non-leachable from the sensing layer. Non-leachability may be accomplished, for example, by providing barriers (e.g., the electrode, substrate, membranes, and/or films) around the sensing layer which prevent the leaching of the components of the sensing layer 64. One example of such a barrier is a microporous membrane or film which allows diffusion of the analyte into the sensing layer 64 to make contact with the components of the sensing layer 64, but reduces or eliminates the diffusion of the sensing layer components (e.g., an electron transfer agent and/or a catalyst) out of the sensing layer 64.

A variety of different sensing layer configurations can be used. In one embodiment, the sensing layer 64 is deposited on the conductive material 56 of a working electrode 58a, as illustrated in Figures 3A and 3B. The sensing layer 64 may extend beyond the conductive material 56 of the working electrode 58a. In some cases, the sensing layer 64 may also extend over the counter electrode 60 or reference electrode 62 without degrading the performance of the glucose sensor. For

those sensors 42 which utilize channels 54 within which the conductive material 56 is deposited, a portion of the sensing layer 64 may be formed within the channel 54 if the conductive material 56 does not fill the channel 54.

5 A sensing layer 64 in direct contact with the working electrode 58a may contain an electron transfer agent to transfer electrons directly or indirectly between the analyte and the working electrode, as well as a catalyst to facilitate a reaction of the analyte. For example, a glucose, lactate, or oxygen electrode may be formed having a sensing layer which contains a catalyst, such as glucose oxidase, lactate oxidase, or laccase, respectively, and an electron transfer agent that facilitates the electrooxidation of the glucose, lactate, or oxygen, respectively.

10 In another embodiment, the sensing layer 64 is not deposited directly on the working electrode 58a. Instead, the sensing layer 64 is spaced apart from the working electrode 58a, as illustrated in Figure 4A, and separated from the working electrode 58a by a separation layer 61. The separation layer 61 typically includes one or more membranes or films. In addition to separating the working electrode 58a from the sensing layer 64, the separation layer 61 may also act as a mass transport limiting layer or an interferent eliminating layer, as described below.

15 Typically, a sensing layer 64, which is not in direct contact with the working electrode 58a, includes a catalyst that facilitates a reaction of the analyte. However, this sensing layer 64 typically does not include an electron transfer agent that transfers electrons directly from the working electrode 58a to the analyte, as the sensing layer 64 is spaced apart from the working electrode 58a. One example of this type of sensor is a glucose or lactate sensor which includes an enzyme (e.g., glucose oxidase or lactate oxidase, respectively) in the sensing layer 64. The glucose or lactate reacts with a second compound (e.g., oxygen) in the presence of the enzyme. The second compound is then electrooxidized or electroreduced at the electrode. Changes in the signal at the electrode indicate changes in the level of the second compound in the fluid and are proportional to changes in glucose or lactate level and, thus, correlate to the analyte level.

20 25 30 In another embodiment, two sensing layers 63, 64 are used, as shown in Figure 4B. Each of the two sensing layers 63, 64 may be independently formed on the working electrode 58a or in proximity to the working electrode 58a. One

sensing layer 64 is typically, although not necessarily, spaced apart from the working electrode 58a. For example, this sensing layer 64 may include a catalyst which catalyzes a reaction of the analyte to form a product compound. The product compound is then electrolyzed in the second sensing layer 63 which may include an
5 electron transfer agent to transfer electrons between the working electrode 58a and the product compound and/or a second catalyst to catalyze a reaction of the product compound to generate a signal at the working electrode 58a.

For example, a glucose or lactate sensor may include a first sensing layer 64 which is spaced apart from the working electrode and contains an enzyme, for
10 example, glucose oxidase or lactate oxidase. The reaction of glucose or lactate in the presence of the appropriate enzyme forms hydrogen peroxide. A second sensing layer 63 is provided directly on the working electrode 58a and contains a peroxidase enzyme and an electron transfer agent to generate a signal at the electrode in
15 response to the hydrogen peroxide. The level of hydrogen peroxide indicated by the sensor then correlates to the level of glucose or lactate. Another sensor which operates similarly can be made using a single sensing layer with both the glucose or lactate oxidase and the peroxidase being deposited in the single sensing layer. Examples of such sensors are described in U.S. Patent No. 5,593,852, U.S. Patent Application No. 08/540,789, and PCT Patent Application No. US98/02403 entitled
20 "Soybean Peroxidase Electrochemical Sensor", filed on February 11, 1998, Attorney Docket No. M&G 12008.8WOI2, incorporated herein by reference.

In some embodiments, one or more of the working electrodes 58b do not have a corresponding sensing layer 64, as shown in Figures 3A and 4A, or have a sensing layer (not shown) which does not contain one or more components (e.g., an
25 electron transfer agent or catalyst) needed to electrolyze the analyte. The signal generated at this working electrode 58b typically arises from interferences and other sources, such as ions, in the fluid, and not in response to the analyte (because the analyte is not electrooxidized or electroreduced). Thus, the signal at this working electrode 58b corresponds to a background signal. The background signal can be
30 removed from the analyte signal obtained from other working electrodes 58a that are associated with fully-functional sensing layers 64 by, for example, subtracting the signal at working electrode 58b from the signal at working electrode 58a.

Sensors having multiple working electrodes 58a may also be used to obtain more precise results by averaging the signals or measurements generated at these working electrodes 58a. In addition, multiple readings at a single working electrode 58a or at multiple working electrodes may be averaged to obtain more precise data.

5

Electron Transfer Agent

In many embodiments, the sensing layer 64 contains one or more electron transfer agents in contact with the conductive material 56 of the working electrode 58, as shown in Figures 3A and 3B. In some embodiments of the invention, there is little or no leaching of the electron transfer agent away from the working electrode 58 during the period in which the sensor 42 is implanted in the patient. A diffusing or leachable (i.e., releasable) electron transfer agent often diffuses into the analyte-containing fluid, thereby reducing the effectiveness of the electrode by reducing the sensitivity of the sensor over time. In addition, a diffusing or leaching electron transfer agent in an implantable sensor 42 may also cause damage to the patient. In these embodiments, preferably, at least 90%, more preferably, at least 95%, and, most preferably, at least 99%, of the electron transfer agent remains disposed on the sensor after immersion in the analyte-containing fluid for 24 hours, and, more preferably, for 72 hours. In particular, for an implantable sensor, preferably, at least 90%, more preferably, at least 95%, and most preferably, at least 99%, of the electron transfer agent remains disposed on the sensor after immersion in the body fluid at 37°C for 24 hours, and, more preferably, for 72 hours.

In some embodiments of the invention, to prevent leaching, the electron transfer agents are bound or otherwise immobilized on the working electrode 58 or between or within one or more membranes or films disposed over the working electrode 58. The electron transfer agent may be immobilized on the working electrode 58 using, for example, a polymeric or sol-gel immobilization technique. Alternatively, the electron transfer agent may be chemically (e.g., ionically, covalently, or coordinatively) bound to the working electrode 58, either directly or indirectly through another molecule, such as a polymer, that is in turn bound to the working electrode 58.

Application of the sensing layer 64 on a working electrode 58a is one method for creating a working surface for the working electrode 58a, as shown in Figures 3A and 3B. The electron transfer agent mediates the transfer of electrons to electrooxidize or electroreduce an analyte and thereby permits a current flow
5 between the working electrode 58 and the counter electrode 60 via the analyte. The mediation of the electron transfer agent facilitates the electrochemical analysis of analytes which are not suited for direct electrochemical reaction on an electrode.

In general, the preferred electron transfer agents are electroreducible and electrooxidizable ions or molecules having redox potentials that are a few hundred
10 millivolts above or below the redox potential of the standard calomel electrode (SCE). Preferably, the electron transfer agents are not more reducing than about -150 mV and not more oxidizing than about +400 mV versus SCE.

The electron transfer agent may be organic, organometallic, or inorganic. Examples of organic redox species are quinones and species that in their oxidized
15 state have quinoid structures, such as Nile blue and indophenol. Some quinones and partially oxidized quinhydrones react with functional groups of proteins such as the thiol groups of cysteine, the amine groups of lysine and arginine, and the phenolic groups of tyrosine which may render those redox species unsuitable for some of the sensors of the present invention because of the presence of the interfering proteins in
20 an analyte-containing fluid. Usually substituted quinones and molecules with quinoid structure are less reactive with proteins and are preferred. A preferred tetrasubstituted quinone usually has carbon atoms in positions 1, 2, 3, and 4.

In general, electron transfer agents suitable for use in the invention have structures or charges which prevent or substantially reduce the diffusional loss of the
25 electron transfer agent during the period of time that the sample is being analyzed. The preferred electron transfer agents include a redox species bound to a polymer which can in turn be immobilized on the working electrode. The bond between the redox species and the polymer may be covalent, coordinative, or ionic. Useful electron transfer agents and methods for producing them are described in U.S. Patent
30 Nos. 5,264,104; 5,356,786; 5,262,035; and 5,320,725, incorporated herein by reference. Although any organic or organometallic redox species can be bound to a polymer and used as an electron transfer agent, the preferred redox species is a

transition metal compound or complex. The preferred transition metal compounds or complexes include osmium, ruthenium, iron, and cobalt compounds or complexes. The most preferred are osmium compounds and complexes. It will be recognized that many of the redox species described below may also be used, typically without a polymeric component, as electron transfer agents in a carrier fluid or in a sensing layer of a sensor where leaching of the electron transfer agent is acceptable.

One type of non-releasable polymeric electron transfer agent contains a redox species covalently bound in a polymeric composition. An example of this type of mediator is poly(vinylferrocene).

Another type of non-releasable electron transfer agent contains an ionically-bound redox species. Typically, this type of mediator includes a charged polymer coupled to an oppositely charged redox species. Examples of this type of mediator include a negatively charged polymer such as Nafion[®] (DuPont) coupled to a positively charged redox species such as an osmium or ruthenium polypyridyl cation. Another example of an ionically-bound mediator is a positively charged polymer such as quaternized poly(4-vinyl pyridine) or poly(1-vinyl imidazole), coupled to a negatively charged redox species such as ferricyanide or ferrocyanide. The preferred ionically-bound redox species is a highly charged redox species bound within an oppositely charged redox polymer.

In another embodiment of the invention, suitable non-releasable electron transfer agents include a redox species coordinatively bound to a polymer. For example, the mediator may be formed by coordination of an osmium or cobalt 2, 2'-bipyridyl complex to poly(1-vinyl imidazole) or poly(4-vinyl pyridine).

The preferred electron transfer agents are osmium transition metal complexes with one or more ligands, each ligand having a nitrogen-containing heterocycle such as 2,2'-bipyridine, 1,10-phenanthroline, or derivatives thereof. Furthermore, the preferred electron transfer agents also have one or more ligands covalently bound in a polymer, each ligand having at least one nitrogen-containing heterocycle, such as pyridine, imidazole, or derivatives thereof. These preferred electron transfer agents exchange electrons rapidly between each other and the working electrodes so that the complex can be rapidly oxidized and reduced.

One example of a particularly useful electron transfer agent includes (a) a polymer or copolymer having pyridine or imidazole functional groups and (b) osmium cations complexed with two ligands, each ligand containing 2,2'-bipyridine, 1,10-phenanthroline, or derivatives thereof, the two ligands not necessarily being the same. Preferred derivatives of 2,2'-bipyridine for complexation with the osmium cation are 4,4'-dimethyl-2,2'-bipyridine and mono-, di-, and polyalkoxy-2,2'-bipyridines, such as 4,4'-dimethoxy-2,2'-bipyridine. Preferred derivatives of 1,10-phenanthroline for complexation with the osmium cation are 4,7-dimethyl-1,10-phenanthroline and mono, di-, and polyalkoxy-1,10-phenanthrolines, such as 4,7-dimethoxy-1,10-phenanthroline. Preferred polymers for complexation with the osmium cation include polymers and copolymers of poly(1-vinyl imidazole) (referred to as "PVI") and poly(4-vinyl pyridine) (referred to as "PVP"). Suitable copolymer substituents of poly(1-vinyl imidazole) include acrylonitrile, acrylamide, and substituted or quaternized N-vinyl imidazole. Most preferred are electron transfer agents with osmium complexed to a polymer or copolymer of poly(1-vinyl imidazole).

The preferred electron transfer agents have a redox potential ranging from -100 mV to about +150 mV versus the standard calomel electrode (SCE). Preferably, the potential of the electron transfer agent ranges from -100 mV to +150 mV and more preferably, the potential ranges from -50 mV to +50 mV. The most preferred electron transfer agents have osmium redox centers and a redox potential ranging from +50 mV to -150 mV versus SCE.

Catalyst

The sensing layer 64 may also include a catalyst which is capable of catalyzing a reaction of the analyte. The catalyst may also, in some embodiments, act as an electron transfer agent. One example of a suitable catalyst is an enzyme which catalyzes a reaction of the analyte. For example, a catalyst, such as a glucose oxidase, glucose dehydrogenase (e.g., pyrroloquinoline quinone glucose dehydrogenase (PQQ)), or oligosaccharide dehydrogenase, may be used when the analyte is glucose. A lactate oxidase or lactate dehydrogenase may be used when the

analyte is lactate. Laccase may be used when the analyte is oxygen or when oxygen is generated or consumed in response to a reaction of the analyte.

Preferably, the catalyst is non-leachably disposed on the sensor, whether the catalyst is part of a solid sensing layer in the sensor or solvated in a fluid within the sensing layer. More preferably, the catalyst is immobilized within the sensor (e.g.,
5 on the electrode and/or within or between a membrane or film) to prevent unwanted leaching of the catalyst away from the working electrode 58 and into the patient. This may be accomplished, for example, by attaching the catalyst to a polymer, cross linking the catalyst with another electron transfer agent (which, as described above,
10 can be polymeric), and/or providing one or more barrier membranes or films with pore sizes smaller than the catalyst.

As described above, a second catalyst may also be used. This second catalyst is often used to catalyze a reaction of a product compound resulting from the catalyzed reaction of the analyte. The second catalyst typically operates with an
15 electron transfer agent to electrolyze the product compound to generate a signal at the working electrode. Alternatively, the second catalyst may be provided in an interferent-eliminating layer to catalyze reactions that remove interferents, as described below.

One embodiment of the invention is an electrochemical sensor in which the
20 catalyst is mixed or dispersed in the conductive material 56 which forms the conductive trace 52 of a working electrode 58. This may be accomplished, for example, by mixing a catalyst, such as an enzyme, in a carbon ink and applying the mixture into a channel 54 on the surface of the substrate 50. Preferably, the catalyst is immobilized in the channel 53 so that it can not leach away from the working
25 electrode 58. This may be accomplished, for example, by curing a binder in the carbon ink using a curing technique appropriate to the binder. Curing techniques include, for example, evaporation of a solvent or dispersant, exposure to ultraviolet light, or exposure to heat. Typically, the mixture is applied under conditions that do not substantially degrade the catalyst. For example, the catalyst may be an enzyme
30 that is heat-sensitive. The enzyme and conductive material mixture should be applied and cured, preferably, without sustained periods of heating. The mixture

may be cured using evaporation or UV curing techniques or by the exposure to heat that is sufficiently short that the catalyst is not substantially degraded.

Another consideration for *in vivo* analyte sensors is the thermostability of the catalyst. Many enzymes have only limited stability at biological temperatures.

5 Thus, it may be necessary to use large amounts of the catalyst and/or use a catalyst that is thermostable at the necessary temperature (e.g., 37°C or higher for normal body temperature). A thermostable catalyst may be defined as a catalyst which loses less than 5% of its activity when held at 37°C for at least one hour, preferably, at least one day, and more preferably at least three days. One example of a
10 thermostable catalyst is soybean peroxidase. This particular thermostable catalyst may be used in a glucose or lactate sensor when combined either in the same or separate sensing layers with glucose or lactate oxidase or dehydrogenase. A further description of thermostable catalysts and their use in electrochemical inventions is found in U.S. Patent No. 5,665,222 U.S. Patent Application No. 08/540,789, and
15 PCT Application No. US98/02403 entitled "Soybean Peroxidase Electrochemical Sensor", filed on February 11, 1998, Attorney Docket No. M&G 12008.8WOI2.

Electrolysis of the Analyte

To electrolyze the analyte, a potential (versus a reference potential) is applied
20 across the working and counter electrodes 58, 60. The minimum magnitude of the applied potential is often dependent on the particular electron transfer agent, analyte (if the analyte is directly electrolyzed at the electrode), or second compound (if a second compound, such as oxygen or hydrogen peroxide, whose level is dependent on the analyte level, is directly electrolyzed at the electrode). The applied potential
25 usually equals or is more oxidizing or reducing, depending on the desired electrochemical reaction, than the redox potential of the electron transfer agent, analyte, or second compound, whichever is directly electrolyzed at the electrode. The potential at the working electrode is typically large enough to drive the electrochemical reaction to or near completion.

30 The magnitude of the potential may optionally be limited to prevent significant (as determined by the current generated in response to the analyte) electrochemical reaction of interferents, such as urate, ascorbate, and

acetaminophen. The limitation of the potential may be obviated if these interferents have been removed in another way, such as by providing an interferent-limiting barrier, as described below, or by including a working electrode 58b (see Figure 3A) from which a background signal may be obtained.

5 When a potential is applied between the working electrode 58 and the counter electrode 60, an electrical current will flow. The current is a result of the electrolysis of the analyte or a second compound whose level is affected by the analyte. In one embodiment, the electrochemical reaction occurs via an electron transfer agent and the optional catalyst. Many analytes B are oxidized (or reduced)
 10 to products C by an electron transfer agent species A in the presence of an appropriate catalyst (e.g., an enzyme). The electron transfer agent A is then oxidized (or reduced) at the electrode. Electrons are collected by (or removed from) the electrode and the resulting current is measured. This process is illustrated by reaction equations (1) and (2) (similar equations may be written for the reduction of
 15 the analyte B by a redox mediator A in the presence of a catalyst):

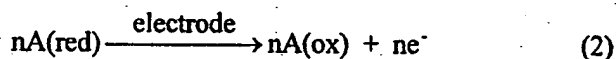
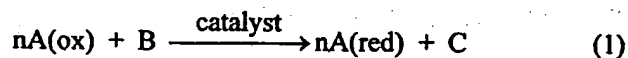

As an example, an electrochemical sensor may be based on the reaction of a glucose molecule with two non-leachable ferricyanide anions in the presence of
 20 glucose oxidase to produce two non-leachable ferrocyanide anions, two hydrogen ions, and gluconolactone. The amount of glucose present is assayed by electrooxidizing the non-leachable ferrocyanide anions to non-leachable ferricyanide anions and measuring the current.

In another embodiment, a second compound whose level is affected by the
 25 analyte is electrolyzed at the working electrode. In some cases, the analyte D and the second compound, in this case, a reactant compound E, such as oxygen, react in the presence of the catalyst, as shown in reaction equation (3).

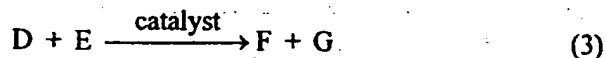

The reactant compound E is then directly oxidized (or reduced) at the working electrode, as shown in reaction equation (4)

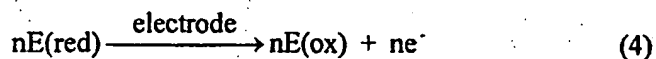

Alternatively, the reactant compound E is indirectly oxidized (or reduced) using an electron transfer agent H (optionally in the presence of a catalyst), that is subsequently reduced or oxidized at the electrode, as shown in reaction equations (5) and (6).

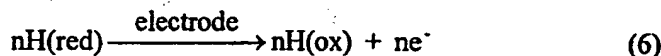
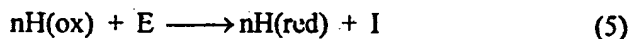

10 In either case, changes in the concentration of the reactant compound, as indicated by the signal at the working electrode, correspond inversely to changes in the analyte (i.e., as the level of analyte increase then the level of reactant compound and the signal at the electrode decreases.)

In other embodiments, the relevant second compound is a product compound F, as shown in reaction equation (3). The product compound F is formed by the catalyzed reaction of analyte D and then be directly electrolyzed at the electrode or indirectly electrolyzed using an electron transfer agent and, optionally, a catalyst. In these embodiments, the signal arising from the direct or indirect electrolysis of the product compound F at the working electrode corresponds directly to the level of the analyte (unless there are other sources of the product compound). As the level of analyte increases, the level of the product compound and signal at the working electrode increases.

Those skilled in the art will recognize that there are many different reactions that will achieve the same result; namely the electrolysis of an analyte or a compound whose level depends on the level of the analyte. Reaction equations (1) through (6) illustrate non-limiting examples of such reactions.

Temperature Probe

A variety of optional items may be included in the sensor. One optional item is a temperature probe 66 (Figures 8 and 11). The temperature probe 66 may be
5 made using a variety of known designs and materials. One exemplary temperature probe 66 is formed using two probe leads 68, 70 connected to each other through a temperature-dependent element 72 that is formed using a material with a temperature-dependent characteristic. An example of a suitable temperature-dependent characteristic is the resistance of the temperature-dependent element 72.

10 The two probe leads 68, 70 are typically formed using a metal, an alloy, a semimetal, such as graphite, a degenerate or highly doped semiconductor, or a small-band gap semiconductor. Examples of suitable materials include gold, silver, ruthenium oxide, titanium nitride, titanium dioxide, indium doped tin oxide, tin doped indium oxide, or graphite. The temperature-dependent element 72 is typically
15 made using a fine trace (e.g., a conductive trace that has a smaller cross-section than that of the probe leads 68, 70) of the same conductive material as the probe leads, or another material such as a carbon ink, a carbon fiber, or platinum, which has a temperature-dependent characteristic, such as resistance, that provides a temperature-dependent signal when a voltage source is attached to the two probe
20 leads 68, 70 of the temperature probe 66. The temperature-dependent characteristic of the temperature-dependent element 72 may either increase or decrease with temperature. Preferably, the temperature dependence of the characteristic of the temperature-dependent element 72 is approximately linear with temperature over the expected range of biological temperatures (about 25 to 45 °C), although this is not
25 required.

Typically, a signal (e.g., a current) having an amplitude or other property that is a function of the temperature can be obtained by providing a potential across the two probe leads 68, 70 of the temperature probe 66. As the temperature changes, the temperature-dependent characteristic of the temperature-dependent element 72
30 increases or decreases with a corresponding change in the signal amplitude. The signal from the temperature probe 66 (e.g., the amount of current flowing through the probe) may be combined with the signal obtained from the working electrode 58

by, for example, scaling the temperature probe signal and then adding or subtracting the scaled temperature probe signal from the signal at the working electrode 58. In this manner, the temperature probe 66 can provide a temperature adjustment for the output from the working electrode 58 to offset the temperature dependence of the
5 working electrode 58.

One embodiment of the temperature probe includes probe leads 68, 70 formed as two spaced-apart channels with a temperature-dependent element 72 formed as a cross-channel connecting the two spaced-apart channels, as illustrated in Figure 8. The two spaced-apart channels contain a conductive material, such as a
10 metal, alloy, semimetal, degenerate semiconductor, or metallic compound. The cross-channel may contain the same material (provided the cross-channel has a smaller cross-section than the two spaced-apart channels) as the probe leads 68, 70. In other embodiments, the material in the cross-channel is different than the material of the probe leads 68, 70.

15 One exemplary method for forming this particular temperature probe includes forming the two spaced-apart channels and then filling them with the metallic or alloyed conductive material. Next, the cross-channel is formed and then filled with the desired material. The material in the cross-channel overlaps with the conductive material in each of the two spaced-apart channels to form an electrical
20 connection.

For proper operation of the temperature probe 66, the temperature-dependent element 72 of the temperature probe 66 can not be shorted by conductive material formed between the two probe leads 68, 70. In addition, to prevent conduction between the two probe leads 68, 70 by ionic species within the body or sample fluid,
25 a covering may be provided over the temperature-dependent element 72, and preferably over the portion of the probe leads 68, 70 that is implanted in the patient. The covering may be, for example, a non-conducting film disposed over the temperature-dependent element 72 and probe leads 68, 70 to prevent the ionic conduction. Suitable non-conducting films include, for example, Kapton™
30 polyimide films (DuPont, Wilmington, DE).

Another method for eliminating or reducing conduction by ionic species in the body or sample fluid is to use an ac voltage source connected to the probe leads

68, 70. In this way, the positive and negative ionic species are alternately attracted and repelled during each half cycle of the ac voltage. This results in no net attraction of the ions in the body or sample fluid to the temperature probe 66. The maximum amplitude of the ac current through the temperature-dependent element 72 may then
5 be used to correct the measurements from the working electrodes 58.

The temperature probe can be placed on the same substrate as the electrodes. Alternatively, a temperature probe may be placed on a separate substrate. In addition, the temperature probe may be used by itself or in conjunction with other devices.

10 Another embodiment of a temperature probe utilizes the temperature dependence of the conductivity of a solution (e.g., blood or interstitial fluid). Typically, the conductivity of an electrolyte-containing solution is dependent on the temperature of the solution, assuming that the concentration of electrolytes is relatively constant. Blood, interstitial fluid, and other bodily fluids are solutions
15 with relatively constant levels of electrolytes. Thus, a sensor 42 can include two or more conductive traces (not shown) which are spaced apart by a known distance. A portion of these conductive traces is exposed to the solution and the conductivity between the exposed portions of the conductive traces is measured using known techniques (e.g., application of a constant or known current or potential and
20 measurement of the resulting potential or current, respectively, to determine the conductivity).

A change in conductivity is related to a change in temperature. This relation can be modeled using linear, quadratic, exponential, or other relations. The parameters for this relationship typically do not vary significantly between most
25 people. The calibration for the temperature probe can be determined by a variety of methods, including, for example, calibration of each sensor 42 using an independent method of determining temperature (e.g., a thermometer, an optical or electrical temperature detector, or the temperature probe 66, described above) or calibrating one sensor 42 and using that calibration for all other sensors in a batch based on
30 uniformity in geometry.

Biocompatible Layer

An optional film layer 75 is formed over at least that portion of the sensor 42 which is subcutaneously inserted into the patient, as shown in Figure 9. This optional film layer 74 may serve one or more functions. The film layer 74 prevents the penetration of large biomolecules into the electrodes. This is accomplished by using a film layer 74 having a pore size that is smaller than the biomolecules that are to be excluded. Such biomolecules may foul the electrodes and/or the sensing layer 64 thereby reducing the effectiveness of the sensor 42 and altering the expected signal amplitude for a given analyte concentration. The fouling of the working electrodes 58 may also decrease the effective life of the sensor 42. The biocompatible layer 74 may also prevent protein adhesion to the sensor 42, formation of blood clots, and other undesirable interactions between the sensor 42 and body.

For example, the sensor may be completely or partially coated on its exterior with a biocompatible coating. A preferred biocompatible coating is a hydrogel which contains at least 20 wt.% fluid when in equilibrium with the analyte-containing fluid. Examples of suitable hydrogels are described in U.S. Patent No. 5,593, 852, incorporated herein by reference, and include crosslinked polyethylene oxides, such as polyethylene oxide tetraacrylate.

Interferent-Eliminating Layer

An interferent-eliminating layer (not shown) may be included in the sensor 42. The interferent-eliminating layer may be incorporated in the biocompatible layer 75 or in the mass transport limiting layer 74 (described below) or may be a separate layer. Interferents are molecules or other species that are electroreduced or electrooxidized at the electrode, either directly or via an electron transfer agent, to produce a false signal. In one embodiment, a film or membrane prevents the penetration of one or more interferents into the region around the working electrodes 58. Preferably, this type of interferent-eliminating layer is much less permeable to one or more of the interferents than to the analyte.

The interferent-eliminating layer may include ionic components, such as Nafion®, incorporated into a polymeric matrix to reduce the permeability of the

interferent-eliminating layer to ionic interferents having the same charge as the ionic components. For example, negatively charged compounds or compounds that form negative ions may be incorporated in the interferent-eliminating layer to reduce the permeation of negative species in the body or sample fluid.

5 Another example of an interferent-eliminating layer includes a catalyst for catalyzing a reaction which removes interferents. One example of such a catalyst is a peroxidase. Hydrogen peroxide reacts with interferents, such as acetaminophen, urate, and ascorbate. The hydrogen peroxide may be added to the analyte-containing fluid or may be generated *in situ*, by, for example, the reaction of glucose or lactate
10 in the presence of glucose oxidase or lactate oxidase, respectively. Examples of interferent eliminating layers include a peroxidase enzyme crosslinked (a) using gluteraldehyde as a crosslinking agent or (b) oxidation of oligosaccharide groups in the peroxidase glycoenzyme with NaIO_4 , followed by coupling of the aldehydes formed to hydrazide groups in a polyacrylamide matrix to form hydrazones are
15 describe in U.S. Patents Nos. 5,262,305 and 5,356,786, incorporated herein by reference.

Mass Transport Limiting Layer

A mass transport limiting layer 74 may be included with the sensor to act as
20 a diffusion-limiting barrier to reduce the rate of mass transport of the analyte, for example, glucose or lactate, into the region around the working electrodes 58. By limiting the diffusion of the analyte, the steady state concentration of the analyte in the proximity of the working electrode 58 (which is proportional to the concentration of the analyte in the body or sample fluid) can be reduced. This extends the upper
25 range of analyte concentrations that can still be accurately measured and may also expand the range in which the current increases approximately linearly with the level of the analyte.

It is preferred that the permeability of the analyte through the film layer 74 vary little or not at all with temperature, so as to reduce or eliminate the variation of
30 current with temperature. For this reason, it is preferred that in the biologically relevant temperature range from about 25°C to about 45°C, and most importantly from 30°C to 40°C, neither the size of the pores in the film nor its hydration or

swelling change excessively. Preferably, the mass transport limiting layer is made using a film that absorbs less than 5 wt.% of fluid over 24 hours. This may reduce or obviate any need for a temperature probe. For implantable sensors, it is preferable that the mass transport limiting layer is made using a film that absorbs
5 less than 5 wt.% of fluid over 24 hours at 37°C.

Particularly useful materials for the film layer 74 are membranes that do not swell in the analyte-containing fluid that the sensor tests. Suitable membranes include 3 to 20,000 nm diameter pores. Membranes having 5 to 500 nm diameter pores with well-defined, uniform pore sizes and high aspect ratios are preferred. In
10 one embodiment, the aspect ratio of the pores is preferably two or greater and more preferably five or greater.

Well-defined and uniform pores can be made by track etching a polymeric membrane using accelerated electrons, ions, or particles emitted by radioactive nuclei. Most preferred are anisotropic, polymeric, track etched membranes that
15 expand less in the direction perpendicular to the pores than in the direction of the pores when heated. Suitable polymeric membranes included polycarbonate membranes from Poretics (Livermore, CA, catalog number 19401, 0.01 μm pore size polycarbonate membrane) and Corning Costar Corp. (Cambridge, MA, NucleoporeTM brand membranes with 0.015 μm pore size). Other polyolefin and
20 polyester films may be used. It is preferred that the permeability of the mass transport limiting membrane changes no more than 4%, preferably, no more than 3%, and, more preferably, no more than 2%, per °C in the range from 30°C to 40°C when the membranes resides in the subcutaneous interstitial fluid.

In some embodiments of the invention, the mass transport limiting layer 74
25 may also limit the flow of oxygen into the sensor 42. This can improve the stability of sensors 42 that are used in situations where variation in the partial pressure of oxygen causes non-linearity in sensor response. In these embodiments, the mass transport limiting layer 74 restricts oxygen transport by at least 40%, preferably at least 60%, and more preferably at least 80%, than the membrane restricts transport
30 of the analyte. For a given type of polymer, films having a greater density (e.g., a density closer to that of the crystalline polymer) are preferred. Polyesters, such as

polyethylene terephthalate, are typically less permeable to oxygen and are, therefore, preferred over polycarbonate membranes.

Anticlotting agent

5 An implantable sensor may also, optionally, have an anticlotting agent disposed on a portion the substrate which is implanted into a patient. This anticlotting agent may reduce or eliminate the clotting of blood or other body fluid around the sensor, particularly after insertion of the sensor. Blood clots may foul the sensor or irreproducibly reduce the amount of analyte which diffuses into the
10 sensor. Examples of useful anticlotting agents include heparin and tissue plasminogen activator (TPA), as well as other known anticlotting agents.

 The anticlotting agent may be applied to at least a portion of that part of the sensor 42 that is to be implanted. The anticlotting agent may be applied, for example, by bath, spraying, brushing, or dipping. The anticlotting agent is allowed
15 to dry on the sensor 42. The anticlotting agent may be immobilized on the surface of the sensor or it may be allowed to diffuse away from the sensor surface. Typically, the quantities of anticlotting agent disposed on the sensor are far below the amounts typically used for treatment of medical conditions involving blood clots and, therefore, have only a limited, localized effect.

20

Sensor Lifetime

The sensor 42 may be designed to be a replaceable component in an *in vivo* analyte monitor, and particularly in an implantable analyte monitor. Typically, the sensor 42 is capable of operation over a period of days. Preferably, the period of operation is at least one day, more preferably at least three days, and most preferably at least one week. The sensor 42 can then be removed and replaced with a new sensor. The lifetime of the sensor 42 may be reduced by the fouling of the electrodes or by the leaching of the electron transfer agent or catalyst. These limitations on the longevity of the sensor 42 can be overcome by the use of a biocompatible layer 75 or non-leachable electron transfer agent and catalyst, respectively, as described above.

Another primary limitation on the lifetime of the sensor 42 is the temperature stability of the catalyst. Many catalysts are enzymes, which are very sensitive to the ambient temperature and may degrade at temperatures of the patient's body (e.g., approximately 37°C for the human body). Thus, robust enzymes should be used where available. The sensor 42 should be replaced when a sufficient amount of the enzyme has been deactivated to introduce an unacceptable amount of error in the measurements.

Insertion Device

An insertion device 120 can be used to subcutaneously insert the sensor 42 into the patient, as illustrated in Figure 12. The insertion device 120 is typically formed using structurally rigid materials, such as metal or rigid plastic. Preferred materials include stainless steel and ABS (acrylonitrile-butadiene-styrene) plastic. In some embodiments, the insertion device 120 is pointed and/or sharp at the tip 121 to facilitate penetration of the skin of the patient. A sharp, thin insertion device may reduce pain felt by the patient upon insertion of the sensor 42. In other embodiments, the tip 121 of the insertion device 120 has other shapes, including a blunt or flat shape. These embodiments may be particularly useful when the insertion device 120 does not penetrate the skin but rather serves as a structural support for the sensor 42 as the sensor 42 is pushed into the skin.

The insertion device 120 may have a variety of cross-sectional shapes, as shown in Figures 13A, 13B, and 13C. The insertion device 120 illustrated in Figure 13A is a flat, planar, pointed strip of rigid material which may be attached or otherwise coupled to the sensor 42 to ease insertion of the sensor 42 into the skin of the patient, as well as to provide structural support to the sensor 42 during insertion. The insertion devices 120 of Figures 13B and 13C are U- or V-shaped implements that support the sensor 42 to limit the amount that the sensor 42 may bend or bow during insertion. The cross-sectional width 124 of the insertion devices 120 illustrated in Figures 13B and 13C is typically 1 mm or less, preferably 700 μm or less, more preferably 500 μm or less, and most preferably 300 μm or less. The cross-sectional height 126 of the insertion device 120 illustrated in Figures 13B and 13C is typically about 1 mm or less, preferably about 700 μm or less, and more preferably about 500 μm or less.

The sensor 42 itself may include optional features to facilitate insertion. For example, the sensor 42 may be pointed at the tip 123 to ease insertion, as illustrated in Figure 12. In addition, the sensor 42 may include a barb 125 which helps retain the sensor 42 in the subcutaneous tissue of the patient. The barb 125 may also assist in anchoring the sensor 42 within the subcutaneous tissue of the patient during operation of the sensor 42. However, the barb 125 is typically small enough that little damage is caused to the subcutaneous tissue when the sensor 42 is removed for replacement. The sensor 42 may also include a notch 127 that can be used in cooperation with a corresponding structure (not shown) in the insertion device to apply pressure against the sensor 42 during insertion, but disengage as the insertion device 120 is removed. One example of such a structure in the insertion device is a rod (not shown) between two opposing sides of an insertion device 120 and at an appropriate height of the insertion device 120.

In operation, the sensor 42 is placed within or next to the insertion device 120 and then a force is provided against the insertion device 120 and/or sensor 42 to carry the sensor 42 into the skin of the patient. In one embodiment, the force is applied to the sensor 42 to push the sensor into the skin, while the insertion device 120 remains stationary and provides structural support to the sensor 42.

Alternatively, the force is applied to the insertion device 120 and optionally to the

sensor 42 to push a portion of both the sensor 42 and the insertion device 120 through the skin of the patient and into the subcutaneous tissue. The insertion device 120 is optionally pulled out of the skin and subcutaneous tissue with the sensor 42 remaining in the subcutaneous tissue due to frictional forces between the sensor 42 and the patient's tissue. If the sensor 42 includes the optional barb 125, then this structure may also facilitate the retention of the sensor 42 within the interstitial tissue as the barb catches in the tissue.

The force applied to the insertion device 120 and/or the sensor 42 may be applied manually or mechanically. Preferably, the sensor 42 is reproducibly inserted through the skin of the patient. In one embodiment, an insertion gun is used to insert the sensor. One example of an insertion gun 200 for inserting a sensor 42 is shown in Figure 26. The insertion gun 200 includes a housing 202 and a carrier 204. The insertion device 120 is typically mounted on the carrier 204 and the sensor 42 is pre-loaded into the insertion device 120. The carrier 204 drives the sensor 42 and, optionally, the insertion device 120 into the skin of the patient using, for example, a cocked or wound spring, a burst of compressed gas, an electromagnet repelled by a second magnet, or the like, within the insertion gun 200. In some instances, for example, when using a spring, the carrier 204 and insertion device may be moved, cocked, or otherwise prepared to be directed towards the skin of the patient.

After the sensor 42 is inserted, the insertion gun 200 may contain a mechanism which pulls the insertion device 120 out of the skin of the patient. Such a mechanism may use a spring, electromagnet, or the like to remove the insertion device 120.

The insertion gun may be reusable. The insertion device 120 is often disposable to avoid the possibility of contamination. Alternatively, the insertion device 120 may be sterilized and reused. In addition, the insertion device 120 and/or the sensor 42 may be coated with an anticlotting agent to prevent fouling of the sensor 42.

In one embodiment, the sensor 42 is injected between 2 to 12 mm into the interstitial tissue of the patient for subcutaneous implantation. Preferably, the sensor is injected 3 to 9 mm, and more preferably 5 to 7 mm, into the interstitial tissue. Other embodiments of the invention, may include sensors implanted in other

portions of the patient, including, for example, in an artery, vein, or organ. The depth of implantation varies depending on the desired implantation target.

Although the sensor 42 may be inserted anywhere in the body, it is often desirable that the insertion site be positioned so that the on-skin sensor control unit 44 can be concealed. In addition, it is often desirable that the insertion site be at a place on the body with a low density of nerve endings to reduce the pain to the patient. Examples of preferred sites for insertion of the sensor 42 and positioning of the on-skin sensor control unit 44 include the abdomen, thigh, leg, upper arm, and shoulder.

An insertion angle is measured from the plane of the skin (i.e., inserting the sensor perpendicular to the skin would be a 90° insertion angle). Insertion angles usually range from 10 to 90°, typically from 15 to 60°, and often from 30 to 45°.

On-skin Sensor Control Unit

The on-skin sensor control unit 44 is configured to be placed on the skin of a patient. The on-skin sensor control unit 44 is optionally formed in a shape that is comfortable to the patient and which may permit concealment, for example, under a patient's clothing. The thigh, leg, upper arm, shoulder, or abdomen are convenient parts of the patient's body for placement of the on-skin sensor control unit 44 to maintain concealment. However, the on-skin sensor control unit 44 may be positioned on other portions of the patient's body. One embodiment of the on-skin sensor control unit 44 has a thin, oval shape to enhance concealment, as illustrated in Figures 14-16. However, other shapes and sizes may be used.

The particular profile, as well as the height, width, length, weight, and volume of the on-skin sensor control unit 44 may vary and depends, at least in part, on the components and associated functions included in the on-skin sensor control unit 44, as discussed below. For example, in some embodiments, the on-skin sensor control unit 44 has a height of 1.3 cm or less, and preferably 0.7 cm or less. In some embodiments, the on-skin sensor control unit 44 has a weight of 90 grams or less, preferably 45 grams or less, and more preferably 25 grams or less. In some embodiments, the on-skin sensor control unit 44 has a volume of about 15 cm³ or

less, preferably about 10 cm³ or less, more preferably about 5 cm³ or less, and most preferably about 2.5 cm³ or less.

The on-skin sensor control unit 44 includes a housing 45, as illustrated in Figures 14-16. The housing 45 is typically formed as a single integral unit that rests on the skin of the patient. The housing 45 typically contains most or all of the electronic components, described below, of the on-skin sensor control unit 44. The on-skin sensor control unit 44 usually includes no additional cables or wires to other electronic components or other devices. If the housing includes two or more parts, then those parts typically fit together to form a single integral unit.

The housing 45 of the on-skin sensor control unit 44, illustrated in Figures 14-16, may be formed using a variety of materials, including, for example, plastic and polymeric materials, particularly rigid thermoplastics and engineering thermoplastics. Suitable materials include, for example, polyvinyl chloride, polyethylene, polypropylene, polystyrene, ABS polymers, and copolymers thereof. The housing 45 of the on-skin sensor control unit 44 may be formed using a variety of techniques including, for example, injection molding, compression molding, casting, and other molding methods. Hollow or recessed regions may be formed in the housing 45 of the on-skin sensor control unit 44. The electronic components of the on-skin sensor control unit 44, described below, and/or other items, such as a battery or a speaker for an audible alarm, may be placed in the hollow or recessed areas.

In some embodiments, conductive contacts 80 are provided on the exterior of the housing 45. In other embodiments, the conductive contacts 80 are provided on the interior of the housing 45, for example, within a hollow or recessed region.

In some embodiments, the electronic components and/or other items are incorporated into the housing 45 of the on-skin sensor control unit 44 as the plastic or polymeric material is molded or otherwise formed. In other embodiments, the electronic components and/or other items are incorporated into the housing 45 as the molded material is cooling or after the molded material has been reheated to make it pliable. Alternatively, the electronic components and/or other items may be secured to the housing 45 using fasteners, such as screws, nuts and bolts, nails, staples, rivets, and the like or adhesives, such as contact adhesives, pressure sensitive

adhesives, glues, epoxies, adhesive resins, and the like. In some cases, the electronic components and/or other items are not affixed to the housing 45 at all.

In some embodiments, the housing 45 of the on-skin sensor control unit 44 is a single piece. The conductive contacts 80 may be formed on the exterior of the housing 45 or on the interior of the housing 45 provided there is a port 78 in the housing 45 through which the sensor 42 can be directed to access the conductive contacts 80.

In other embodiments, the housing 45 of the on-skin sensor control unit 44 is formed in at least two separate portions that fit together to form the housing 45, for example, a base 74 and a cover 76, as illustrated in Figures 14-16. The two or more portions of the housing 45 may be entirely separate from each other. Alternatively, at least some of the two or more portions of the housing 45 may be connected together, for example, by a hinge, to facilitate the coupling of the portions to form the housing 45 of the on-skin sensor control unit 44.

These two or more separate portions of the housing 45 of the on-skin sensor control unit 44 may have complementary, interlocking structures, such as, for example, interlocking ridges or a ridge on one component and a complementary groove on another component, so that the two or more separate components may be easily and/or firmly coupled together. This may be useful, particularly if the components are taken apart and fit together occasionally, for example, when a battery or sensor 42 is replaced. However, other fasteners may also be used to couple the two or more components together, including, for example, screws, nuts and bolts, nails, staples, rivets, or the like. In addition, adhesives, both permanent or temporary, may be used including, for example, contact adhesives, pressure sensitive adhesives, glues, epoxies, adhesive resins, and the like.

Typically, the housing 45 is at least water resistant to prevent the flow of fluids into contact with the components in the housing, including, for example, the conductive contacts 80. Preferably, the housing is waterproof. In one embodiment, two or more components of the housing 45, for example, the base 74 and the cover 76, fit together tightly to form a hermetic, waterproof, or water resistant seal so that fluids can not flow into the interior of the on-skin sensor control unit 44. This may be useful to avoid corrosion currents and/or degradation of items within the on-skin

sensor control unit 44, such as the conductive contacts, the battery, or the electronic components, particularly when the patient engages in such activities as showering, bathing, or swimming.

Water resistant, as used herein, means that there is no penetration of water
5 through a water resistant seal or housing when immersed in water at a depth of one meter at sea level. Waterproof, as used herein, means that there is no penetration of water through the waterproof seal or housing when immersed in water at a depth of ten meters, and preferably fifty meters, at sea level. It is often desirable that the electronic circuitry, power supply (e.g., battery), and conductive contacts of the on-
10 skin sensor control unit, as well as the contact pads of the sensor, are contained in a water resistant, and preferably, a waterproof, environment.

In addition to the portions of the housing 45, such as the base 74 and cover 76, there may be other individually-formed pieces of the on-skin sensor control unit 44, which may be assembled during or after manufacture. One example of an
15 individually-formed piece is a cover for electronic components that fits a recess in the base 74 or cover 76. Another example is a cover for a battery provided in the base 74 or cover 76. These individually-formed pieces of the on-skin sensor control unit 44 may be permanently affixed, such as, for example, a cover for electronic components, or removably affixed, such as, for example, a removable cover for a
20 battery, to the base 74, cover 76, or other component of the on-skin sensor control unit 44. Methods for affixing these individually-formed pieces include the use of fasteners, such as screws, nuts and bolts, staples, nails, rivets, and the like, frictional fasteners, such as tongue and groove structures, and adhesives, such as contact adhesives, pressure sensitive adhesives, glues, epoxies, adhesive resins, and the like.

25 One embodiment of the on-skin sensor control unit 44 is a disposable unit complete with a battery for operating the unit. There are no portions of the unit that the patient needs to open or remove, thereby reducing the size of the unit and simplifying its construction. The on-skin sensor control unit 44 optionally remains in a sleep mode prior to use to conserve the battery's power. The on-skin sensor
30 control unit 44 detects that it is being used and activates itself. Detection of use may be through a number of mechanisms. These include, for example, detection of a change in resistance across the electrical contacts, actuation of a switch upon mating

the on-skin sensor control unit 44 with a mounting unit 77 (see Figures 27A and 28A). The on-skin sensor control unit 44 is typically replaced when it no longer operates within threshold limits, for example, if the battery or other power source does not generate sufficient power. Often this embodiment of the on-skin sensor control unit 44 has conductive contacts 80 on the exterior of the housing 45. Once the sensor 42 is implanted in the patient, the sensor control unit 44 is placed over the sensor 42 with the conductive contacts 80 in contact with the contact pads 49 of the sensor 42.

The on-skin sensor control unit 44 is typically attached to the skin 75 of the patient, as illustrated in Figure 17. The on-skin sensor control unit 44 may be attached by a variety of techniques including, for example, by adhering the on-skin sensor control unit 44 directly to the skin 75 of the patient with an adhesive provided on at least a portion of the housing 45 of the on-skin sensor control unit 44 which contacts the skin 75 or by suturing the on-skin sensor control unit 44 to the skin 75 through suture openings (not shown) in the sensor control unit 44.

Another method of attaching the housing 45 of the on-skin sensor control unit 44 to the skin 75 includes using a mounting unit, 77. The mounting unit 77 is often a part of the on-skin sensor control unit 44. One example of a suitable mounting unit 77 is a double-sided adhesive strip, one side of which is adhered to a surface of the skin of the patient and the other side is adhered to the on-skin sensor control unit 44. In this embodiment, the mounting unit 77 may have an optional opening 79 which is large enough to allow insertion of the sensor 42 through the opening 79. Alternatively, the sensor may be inserted through a thin adhesive and into the skin.

A variety of adhesives may be used to adhere the on-skin sensor control unit 44 to the skin 75 of the patient, either directly or using the mounting unit 77, including, for example, pressure sensitive adhesives (PSA) or contact adhesives. Preferably, an adhesive is chosen which is not irritating to all or a majority of patients for at least the period of time that a particular sensor 42 is implanted in the patient. Alternatively, a second adhesive or other skin-protecting compound may be included with the mounting unit so that a patient, whose skin is irritated by the adhesive on the mounting unit 77, can cover his skin with the second adhesive or

other skin-protecting compound and then place the mounting unit 77 over the second adhesive or other skin-protecting compound. This should substantially prevent the irritation of the skin of the patient because the adhesive on the mounting unit 77 is no longer in contact with the skin, but is instead in contact with the second adhesive or other skin-protecting compound.

When the sensor 42 is changed, the on-skin sensor control unit 44 may be moved to a different position on the skin 75 of the patient, for example, to avoid excessive irritation. Alternatively, the on-skin sensor control unit 44 may remain at the same place on the skin of the patient until it is determined that the unit 44 should be moved.

Another embodiment of a mounting unit 77 used in an on-skin sensor control unit 44 is illustrated in Figures 27A and 27B. The mounting unit 77 and a housing 45 of an on-skin sensor control unit 44 are mounted together in, for example, an interlocking manner, as shown in Figure 27A. The mounting unit 77 is formed, for example, using plastic or polymer materials, including, for example, polyvinyl chloride, polyethylene, polypropylene, polystyrene, ABS polymers, and copolymers thereof. The mounting unit 77 may be formed using a variety of techniques including, for example, injection molding, compression molding, casting, and other molding methods.

The mounting unit 77 typically includes an adhesive on a bottom surface of the mounting unit 77 to adhere to the skin of the patient or the mounting unit 77 is used in conjunction with, for example, double-sided adhesive tape or the like. The mounting unit 77 typically includes an opening 79 through which the sensor 42 is inserted, as shown in Figure 27B. The mounting unit 77 may also include a support structure 220 for holding the sensor 42 in place and against the conductive contacts 80 on the on-skin sensor control unit 42. The mounting unit 77, also, optionally, includes a positioning structure 222, such as an extension of material from the mounting unit 77, that corresponds to a structure (not shown), such as an opening, on the sensor 42 to facilitate proper positioning of the sensor 42, for example, by aligning the two complementary structures.

In another embodiment, a coupled mounting unit 77 and housing 45 of an on-skin sensor control unit 44 is provided on an adhesive patch 204 with an optional

cover 206 to protect and/or confine the housing 45 of the on-skin sensor control unit 44, as illustrated in Figure 28A. The optional cover may contain an adhesive or other mechanism for attachment to the housing 45 and/or mounting unit 77. The mounting unit 77 typically includes an opening 49 through which a sensor 42 is
5 disposed, as shown in Figure 28B. The opening 49 may optionally be configured to allow insertion of the sensor 42 through the opening 49 using an insertion device 120 or insertion gun 200 (see Figure 26). The housing 45 of the on-skin sensor control unit 44 has a base 74 and a cover 76, as illustrated in Figure 28C. A bottom
10 view of the housing 45, as shown in Figure 28D, illustrates ports 230 through which conductive contacts (not shown) extend to connect with contact pads on the sensor 42. A board 232 for attachment of circuit components may optionally be provided within the on-skin sensor control unit 44, as illustrated in Figure 28E.

In some embodiments, the adhesive on the on-skin sensor control unit 44 and/or on any of the embodiments of the mounting unit 77 is water resistant or
15 waterproof to permit activities such as showering and/or bathing while maintaining adherence of the on-skin sensor control unit 44 to the skin 75 of the patient and, at least in some embodiments, preventing water from penetrating into the sensor control unit 44. The use of a water resistant or waterproof adhesive combined with a water resistant or waterproof housing 45 protects the components in the sensor
20 control unit 44 and the contact between the conductive contacts 80 and the sensor 42 from damage or corrosion. An example of a non-irritating adhesive that repels water is Tegaderm (3M, St. Paul, MN).

In one embodiment, the on-skin sensor control unit 44 includes a sensor port 78 through which the sensor 42 enters the subcutaneous tissue of the patient, as
25 shown in Figures 14 to 16. The sensor 42 may be inserted into the subcutaneous tissue of the patient through the sensor port 78. The on-skin sensor control unit 44 may then be placed on the skin of the patient with the sensor 42 being threaded through the sensor port 78. If the housing 45 of the sensor 42 has, for example, a base 74 and a cover 76, then the cover 76 may be removed to allow the patient to
30 guide the sensor 42 into the proper position for contact with the conductive contacts 80.

Alternatively, if the conductive contacts 80 are within the housing 45 the patient may slide the sensor 42 into the housing 45 until contact is made between the contact pads 49 and the conductive contacts 80. The sensor control unit 44 may have a structure which obstructs the sliding of the sensor 42 further into the housing
5 once the sensor 42 is properly positioned with the contact pads 49 in contact with the conductive contacts 80.

In other embodiments, the conductive contacts 80 are on the exterior of the housing 45 (see e.g., Figures 27A-27B and 28A-28E). In these embodiments, the patient guides the contacts pads 49 of the sensor 42 into contact with the conductive
10 contacts 80. In some cases, a guiding structure may be provided on the housing 45 which guides the sensor 42 into the proper position. An example of such a structure includes a set of guiding rails extending from the housing 45 and having the shape of the sensor 42.

In some embodiments, when the sensor 42 is inserted using an insertion
15 device 120 (see Figure 12), the tip of the insertion device 120 or optional insertion gun 200 (see Figure 26) is positioned against the skin or the mounting unit 77 at the desired insertion point. In some embodiments, the insertion device 120 is positioned on the skin without any guide. In other embodiments, the insertion device 120 or
20 insertion gun 200 is positioned using guides (not shown) in the mounting unit 77 or other portion of the on-skin sensor control unit 44. In some embodiments, the guides, opening 79 in the mounting unit 77 and/or sensor port 78 in the housing 45 of the on-skin sensor control unit 44 have a shape which is complementary to the shape of the tip of the insertion device 120 and/or insertion gun 200 to limit the
25 orientation of the insertion device 120 and/or insertion gun 200 relative to the opening 79 and/or sensor port 78. The sensor can then be subcutaneously inserted into the patient by matching the complementary shape of the opening 79 or sensor port 78 with the insertion device 120 and/or insertion gun 200.

In some embodiments, the shapes of a) the guides, opening 79, or sensor port
30 78, and (b) the insertion device 120 or insertion gun 200 are configured such that the two shapes can only be matched in a single orientation. This aids in inserting the sensor 42 in the same orientation each time a new sensor is inserted into the patient. This uniformity in insertion orientation may be required in some embodiments to

ensure that the contact pads 49 on the sensor 42 are correctly aligned with appropriate conductive contacts 80 on the on-skin sensor control unit 44. In addition, the use of the insertion gun, as described above, may ensure that the sensor 42 is inserted at a uniform, reproducible depth.

5 The sensor 42 and the electronic components within the on-skin sensor control unit 44 are coupled via conductive contacts 80, as shown in Figures 14-16. The one or more working electrodes 58, counter electrode 60 (or counter/reference electrode), optional reference electrode 62, and optional temperature probe 66 are attached to individual conductive contacts 80. In the illustrated embodiment of
10 Figures 14-16, the conductive contacts 80 are provided on the interior of the on-skin sensor control unit 44. Other embodiments of the on-skin sensor control unit 44 have the conductive contacts disposed on the exterior of the housing 45. The placement of the conductive contacts 80 is such that they are in contact with the contact pads 49 on the sensor 42 when the sensor 42 is properly positioned within
15 the on-skin sensor control unit 44.

 In the illustrated embodiment of Figures 14-16, the base 74 and cover 76 of the on-skin sensor control unit 44 are formed such that, when the sensor 42 is within the on-skin sensor control unit 44 and the base 74 and cover 76 are fitted together, the sensor 42 is bent. In this manner, the contact pads 49 on the sensor 42 are
20 brought into contact with the conductive contacts 80 of the on-skin sensor control unit 44. The on-skin sensor control unit 44 may optionally contain a support structure 82 to hold, support, and/or guide the sensor 42 into the correct position.

 Non-limiting examples of suitable conductive contacts 80 are illustrated in Figures 19A-19D. In one embodiment, the conductive contacts 80 are pins 84 or the
25 like, as illustrated in Figure 19A, which are brought into contact with the contact pads 49 on the sensor 42 when the components of the on-skin sensor control unit 44, for example, the base 74 and cover 76, are fitted together. A support 82 may be provided under the sensor 42 to promote adequate contact between the contact pads 49 on the sensor 42 and the pins 84. The pins are typically made using a
30 conductive material, such as a metal or alloy, for example, copper, stainless steel, or silver. Each pin has a distal end that extends from the on-skin sensor control unit 44 for contacting the contact pads 49 on the sensor 42. Each pin 84 also has a proximal

end that is coupled to a wire or other conductive strip that is, in turn, coupled to the rest of the electronic components (e.g., the voltage source 95 and measurement circuit 96 of Figures 18A and 18B) within the on-skin sensor control unit 44.

Alternatively, the pins 84 may be coupled directly to the rest of the electronics.

5 In another embodiment, the conductive contacts 80 are formed as a series of conducting regions 88 with interspersed insulating regions 90, as illustrated in Figure 19B. The conducting regions 88 may be as large or larger than the contact pads 49 on the sensor 42 to alleviate registration concerns. However, the insulating regions 90 should have sufficient width so that a single conductive region 88 does
10 not overlap with two contact pads 49 as determined based on the expected variation in the position of the sensor 42 and contact pads 49 with respect to the conductive contacts 80. The conducting regions 88 are formed using materials such as metals, alloys, or conductive carbon. The insulating regions 90 may be formed using known insulating materials including, for example, insulating plastic or polymer materials.

15 In a further embodiment, a unidirectional conducting adhesive 92 may be used between the contact pads 49 on the sensor 42 and conductive contacts 80 implanted or otherwise formed in the on-skin sensor control unit 44, as shown in Figure 19C.

 In yet another embodiment, the conductive contacts 80 are conductive
20 members 94 that extend from a surface of the on-skin sensor control unit 44 to contact the contact pads 49, as shown in Figure 19D. A variety of different shapes may be used for these members, however, they should be electrically insulated from each other. The conductive members 94 may be made using metal, alloy, conductive carbon, or conducting plastics and polymers.

25 Any of the exemplary conductive contacts 80 described above may extend from either the upper surface of the interior of the on-skin sensor control unit 44, as illustrated in Figure 19A-19C, or from the lower surface of the interior of the on-skin sensor control unit 44, as illustrated in Figure 19D, or from both the upper and lower surfaces of the interior of the on-skin sensor control unit 44, particularly when
30 the sensor 42 has contact pads 49 on both sides of the sensor.

 Conductive contacts 80 on the exterior of the housing 45 may also have a variety of shapes as indicated in Figures 19E and 19F. For example, the conductive

contacts 80 may be embedded in (Figure 19E) or extending out of (Figure 19F) the housing 45.

The conductive contacts 80 are preferably made using a material which will not corrode due to contact with the contact pads 49 of the sensor 42. Corrosion may occur when two different metals are brought in contact. Thus, if the contact pads 49 are formed using carbon then the preferred conductive contacts 80 may be made using any material, including metals or alloys. However, if any of the contact pads 49 are made with a metal or alloy then the preferred conductive contacts 80 for coupling with the metallic contact pads are made using a non-metallic conductive material, such as conductive carbon or a conductive polymer, or the conductive contacts 80 and the contact pads 49 are separated by a non-metallic material, such as a unidirectional conductive adhesive.

In one embodiment, electrical contacts are eliminated between the sensor 42 and the on-skin sensor control unit 44. Power is transmitted to the sensor via inductive coupling, using, for example, closely space antennas (e.g., facing coils) (not shown) on the sensor and the on-skin sensor control unit. Changes in the electrical characteristics of the sensor control unit 44 (e.g., current) induce a changing magnetic field in the proximity of the antenna. The changing magnetic field induces a current in the antenna of the sensor. The close proximity of the sensor and on-skin sensor control unit results in reasonably efficient power transmission. The induced current in the sensor may be used to power potentiostats, operational amplifiers, capacitors, integrated circuits, transmitters, and other electronic components built into the sensor structure. Data is transmitted back to the sensor control unit, using, for example, inductive coupling via the same or different antennas and/or transmission of the signal via a transmitter on the sensor. The use of inductive coupling can eliminate electrical contacts between the sensor and the on-skin sensor control unit. Such contacts are commonly a source of noise and failure. Moreover, the sensor control unit may then be entirely sealed which may increase the waterproofing of the on-skin sensor control unit.

An exemplary on-skin sensor control unit 44 can be prepared and used in the following manner. A mounting unit 77 having adhesive on the bottom is applied to the skin. An insertion gun 200 (see Figure 26) carrying the sensor 42 and the

insertion device 120 is positioned against the mounting unit 77. The insertion gun 200 and mounting unit 77 are optionally designed such that there is only one position in which the two properly mate. The insertion gun 200 is activated and a portion of the sensor 42 and optionally a portion of the insertion device 120 are driven through the skin into, for example, the subcutaneous tissue. The insertion gun 200 withdraws the insertion device 200, leaving the portion of the sensor 42 inserted through the skin. The housing 45 of the on-skin control unit 44 is then coupled to the mounting unit 77. Optionally, the housing 45 and the mounting unit 77 are formed such that there is only one position in which the two properly mate. The mating of the housing 45 and the mounting unit 77 establishes contact between the contact pads 49 (see e.g., Figure 2) on the sensor 42 and the conductive contacts 80 on the on-skin sensor control unit 44. Optionally, this action activates the on-skin sensor control unit 44 to begin operation.

15 **On-Skin Control Unit Electronics**

The on-skin sensor control unit 44 also typically includes at least a portion of the electronic components that operate the sensor 42 and the analyte monitoring device system 40. One embodiment of the electronics in the on-skin control unit 44 is illustrated as a block diagram in Figure 18A. The electronic components of the on-skin sensor control unit 44 typically include a power supply 95 for operating the on-skin control unit 44 and the sensor 42, a sensor circuit 97 for obtaining signals from and operating the sensor 42, a measurement circuit 96 that converts sensor signals to a desired format, and a processing circuit 109 that, at minimum, obtains signals from the sensor circuit 97 and/or measurement circuit 96 and provides the signals to an optional transmitter 98. In some embodiments, the processing circuit 109 may also partially or completely evaluate the signals from the sensor 42 and convey the resulting data to the optional transmitter 98 and/or activate an optional alarm system 94 (see Figure 18B) if the analyte level exceeds a threshold. The processing circuit 109 often includes digital logic circuitry.

30 The on-skin sensor control unit 44 may optionally contain a transmitter 98 for transmitting the sensor signals or processed data from the processing circuit 109 to a receiver/display unit 46, 48; a data storage unit 102 for temporarily or

permanently storing data from the processing circuit 109; a temperature probe circuit 99 for receiving signals from and operating a temperature probe 66; a reference voltage generator 101 for providing a reference voltage for comparison with sensor-generated signals; and/or a watchdog circuit 103 that monitors the operation of the electronic components in the on-skin sensor control unit 44.

Moreover, the sensor control unit 44 often includes digital and/or analog components utilizing semiconductor devices, such as transistors. To operate these semiconductor devices, the on-skin control unit 44 may include other components including, for example, a bias control generator 105 to correctly bias analog and digital semiconductor devices, an oscillator 107 to provide a clock signal, and a digital logic and timing component 109 to provide timing signals and logic operations for the digital components of the circuit.

As an example of the operation of these components, the sensor circuit 97 and the optional temperature probe circuit 99 provide raw signals from the sensor 42 to the measurement circuit 96. The measurement circuit 96 converts the raw signals to a desired format, using for example, a current-to-voltage converter, current-to-frequency converter, and/or a binary counter or other indicator that produces a signal proportional to the absolute value of the raw signal. This may be used, for example, to convert the raw signal to a format that can be used by digital logic circuits. The processing circuit 109 may then, optionally, evaluate the data and provide commands to operate the electronics.

Figure 18B illustrates a block diagram of another exemplary on-skin control unit 44 that also includes optional components such as a receiver 99 to receive, for example, calibration data; a calibration storage unit 100 to hold, for example, factory-set calibration data, calibration data obtained via the receiver 99 and/or operational signals received, for example, from a receiver/display unit 46, 48 or other external device; an alarm system 104 for warning the patient; and a deactivation switch 111 to turn off the alarm system.

Functions of the analyte monitoring system 40 and the sensor control unit 44 may be implemented using either software routines, hardware components, or combinations thereof. The hardware components may be implemented using a variety of technologies, including, for example, integrated circuits or discrete

electronic components. The use of integrated circuits typically reduces the size of the electronics, which in turn may result in a smaller on-skin sensor control unit 44.

The electronics in the on-skin sensor control unit 44 and the sensor 42 are operated using a power supply 95. One example of a suitable power supply 95 is a battery, for example, a thin circular battery, such as those used in many watches, hearing aids, and other small electronic devices. Preferably, the battery has a lifetime of at least 30 days, more preferably, a lifetime of at least three months, and most preferably, a lifetime of at least one year. The battery is often one of the largest components in the on-skin control unit 44, so it is often desirable to minimize the size of the battery. For example, a preferred battery's thickness is 0.5 mm or less, preferably 0.35 mm or less, and most preferably 0.2 mm or less. Although multiple batteries may be used, it is typically preferred to use only one battery.

The sensor circuit 97 is coupled via the conductive contacts 80 of the sensor control unit 44 to one or more sensors 42, 42'. Each of the sensors represents, at minimum, a working electrode 58, a counter electrode 60 (or counter/reference electrode), and an optional reference electrode 62. When two or more sensors 42, 42' are used, the sensors typically have individual working electrodes 58, but may share a counter electrode 60, counter/reference electrode, and/or reference electrode 52.

The sensor circuit 97 receives signals from and operates the sensor 42 or sensors 42, 42'. The sensor circuit 97 may obtain signals from the sensor 42 using amperometric, coulometric, potentiometric, voltammetric, and/or other electrochemical techniques. The sensor circuit 97 is exemplified herein as obtaining amperometric signals from the sensor 42, however, it will be understood that the sensor circuit can be appropriately configured for obtaining signals using other electrochemical techniques. To obtain amperometric measurements, the sensor circuit 97 typically includes a potentiostat that provides a constant potential to the sensor 42. In other embodiments, the sensor circuit 97 includes an amperostat that supplies a constant current to the sensor 42 and can be used to obtain coulometric or potentiometric measurements.

The signal from the sensor 42 generally has at least one characteristic, such as, for example, current, voltage, or frequency, which varies with the concentration

of the analyte. For example, if the sensor circuit 97 operates using amperometry, then the signal current varies with analyte concentration. The measurement-circuit 96 may include circuitry which converts the information-carrying portion of the signal from one characteristic to another. For example, the measurement circuit 96
5 may include a current-to-voltage or current-to-frequency converter. The purpose of this conversion may be to provide a signal that is, for example, more easily transmitted, readable by digital circuits, and/or less susceptible to noise contributions.

One example of a standard current-to-voltage converter is provided in Figure
10 20A. In this converter, the signal from the sensor 42 is provided at one input terminal 134 of an operational amplifier 130 ("op amp") and coupled through a resistor 138 to an output terminal 136. This particular current-to-voltage converter 131 may, however, be difficult to implement in a small CMOS chip because resistors are often difficult to implement on an integrated circuit. Typically, discrete
15 resistor components are used. However, the used of discrete components increases the space needed for the circuitry.

An alternative current-to-voltage converter 141 is illustrated in Figure 20B. This converter includes an op amp 140 with the signal from the sensor 42 provided at input terminal 144 and a reference potential provided at input terminal 142. A
20 capacitor 145 is placed between the input terminal 144 and the output terminal 146. In addition, switches 147a, 147b, 149a, and 149b are provided to allow the capacitor to charge and discharge at a rate determined by a clock (CLK) frequency. In operation, during one half cycle, switches 147a and 147b close and switches 149a and 149b open allowing the capacitor 145 to charge due to the attached potential V_1 .
25 During the other half cycle, switches 147a and 147b open and switches 149a and 149b close to ground and allow the capacitor 145 to partially or fully discharge. The reactive impedance of the capacitor 145 is analogous to the resistance of the resistor 138 (see Figure 20A), allowing the capacitor 145 to emulate a resistor. The value of this "resistor" depends on the capacitance of the capacitor 145 and the clock
30 frequency. By altering the clock frequency, the reactive impedance ("resistance value") of the capacitor changes. The value of the impedance ("resistance") of the capacitor 145 may be altered by changing the clock frequency. Switches 147a,

147b, 149a, and 149b may be implemented in a CMOS chip using, for example, transistors.

A current-to-frequency converter may also be used in the measurement circuit 96. One suitable current-to-frequency converter includes charging a capacitor using the signal from the sensor 42. When the potential across the capacitor exceeds a threshold value, the capacitor is allowed to discharge. Thus, the larger the current from the sensor 42, the quicker the threshold potential is achieved. This results in a signal across the capacitor that has an alternating characteristic, corresponding to the charging and discharging of the capacitor, having a frequency which increases with an increase in current from the sensor 42.

In some embodiments, the analyte monitoring system 40 includes two or more working electrodes 58 distributed over one or more sensors 42. These working electrodes 58 may be used for quality control purposes. For example, the output signals and/or analyzed data derived using the two or more working electrodes 58 may be compared to determine if the signals from the working electrodes agree within a desired level of tolerance. If the output signals do not agree, then the patient may be alerted to replace the sensor or sensors. In some embodiments, the patient is alerted only if the lack of agreement between the two sensors persists for a predetermined period of time. The comparison of the two signals may be made for each measurement or at regular intervals. Alternatively or additionally, the comparison may be initiated by the patient or another person. Moreover, the signals from both sensors may be used to generate data or one signal may be discarded after the comparison.

Alternatively, if, for example, two working electrodes 58 have a common counter electrode 60 and the analyte concentration is measured by amperometry, then the current at the counter electrode 60 should be twice the current at each of the working electrodes, within a predetermined tolerance level, if the working electrodes are operating properly. If not, then the sensor or sensors should be replaced, as described above.

An example of using signals from only one working electrode for quality control includes comparing consecutive readings obtained using the single working electrode to determine if they differ by more than a threshold level. If the difference

is greater than the threshold level for one reading or over a period of time or for a predetermined number of readings within a period of time then the patient is alerted to replace the sensor 42. Typically, the consecutive readings and/or the threshold level are determined such that all expected excursions of the sensor signal are within the desired parameters (i.e., the sensor control unit 44 does not consider true changes in analyte concentration to be a sensor failure).

The sensor control unit 44 may also optionally include a temperature probe circuit 99. The temperature probe circuit 99 provides a constant current through (or constant potential) across the temperature probe 66. The resulting potential (or current) varies according to the resistance of the temperature dependent element 72.

The output from the sensor circuit 97 and optional temperature probe circuit is coupled into a measurement circuit 96 that obtains signals from the sensor circuit 97 and optional temperature probe circuit 99 and, at least in some embodiments, provides output data in a form that, for example can be read by digital circuits. The signals from the measurement circuit 96 are sent to the processing circuit 109, which in turn may provide data to an optional transmitter 98. The processing circuit 109 may have one or more of the following functions: 1) transfer the signals from the measurement circuit 96 to the transmitter 98, 2) transfer signals from the measurement circuit 96 to the data storage circuit 102, 3) convert the information-carrying characteristic of the signals from one characteristic to another (when, for example, that has not been done by the measurement circuit 96), using, for example, a current-to-voltage converter, a current-to-frequency converter, or a voltage-to-current converter, 4) modify the signals from the sensor circuit 97 using calibration data and/or output from the temperature probe circuit 99, 5) determine a level of an analyte in the interstitial fluid, 6) determine a level of an analyte in the bloodstream based on the sensor signals obtained from interstitial fluid, 7) determine if the level, rate of change, and/or acceleration in the rate of change of the analyte exceeds or meets one or more threshold values, 8) activate an alarm if a threshold value is met or exceeded, 9) evaluate trends in the level of an analyte based on a series of sensor signals, 10) determine a dose of a medication, and 11) reduce noise and/or errors, for example, through signal averaging or comparing readings from multiple working electrodes 58.

The processing circuit 109 may be simple and perform only one or a small number of these functions or the processing circuit 109 may be more sophisticated and perform all or most of these functions. The size of the on-skin sensor control unit 44 may increase with the increasing number of functions and complexity of those functions that the processing circuit 109 performs. Many of these functions may not be performed by a processing circuit 109 in the on-skin sensor control unit 44, but may be performed by another analyzer 152 in the receiver/display units 46, 48 (see Figure 22).

One embodiment of the measurement circuit 96 and/or processing circuit 109 provides as output data, the current flowing between the working electrode 58 and the counter electrode 60. The measurement circuit 96 and/or processing circuit 109 may also provide as output data a signal from the optional temperature probe 66 which indicates the temperature of the sensor 42. This signal from the temperature probe 66 may be as simple as a current through the temperature probe 66 or the processing circuit 109 may include a device that determines a resistance of the temperature probe 66 from the signal obtained from the measurement circuit 96 for correlation with the temperature of the sensor 42. The output data may then be sent to a transmitter 98 that then transmits this data to at least one receiver/display device 46,48.

Returning to the processing circuit 109, in some embodiments processing circuit 109 is more sophisticated and is capable of determining the analyte concentration or some measure representative of the analyte concentration, such as a current or voltage value. The processing circuit 109 may incorporate the signal of the temperature probe to make a temperature correction in the signal or analyzed data from the working electrode 58. This may include, for example, scaling the temperature probe measurement and adding or subtracting the scaled measurement to the signal or analyzed data from the working electrode 58. The processing circuit 109 may also incorporate calibration data which has been received from an external source or has been incorporated into the processing circuit 109, both of which are described below, to correct the signal or analyzed data from the working electrode 58. Additionally, the processing circuit 109 may include a correction algorithm for converting interstitial analyte level to blood analyte level. The conversion of

interstitial analyte level to blood analyte level is described, for example, in Schmidtke, et al., "Measurement and Modeling of the Transient Difference Between Blood and Subcutaneous Glucose Concentrations in the Rat after Injection of Insulin", Proc. of the Nat'l Acad. of Science, 95, 294-299 (1998) and Quinn, et al.,
5 "Kinetics of Glucose Delivery to Subcutaneous Tissue in Rats Measured with 0.3mm Amperometric Microsensors", Am. J. Physiol., 269 (Endocrinol. Metab. 32), E155-E161 (1995), incorporated herein by reference.

In some embodiments, the data from the processing circuit 109 is analyzed and directed to an alarm system 94 (see Figure 18B) to warn the user. In at least
10 some of these embodiments, a transmitter is not used as the sensor control unit performs all of the needed functions including analyzing the data and warning the patient.

However, in many embodiments, the data (e.g., a current signal, a converted voltage or frequency signal, or fully or partially analyzed data) from processing
15 circuit 109 is transmitted to one or more receiver/display units 46, 48 using a transmitter 98 in the on-skin sensor control unit 44. The transmitter has an antenna 93, such as a wire or similar conductor, formed in the housing 45. The transmitter 98 is typically designed to transmit a signal up to about 2 meters or more, preferably up to about 5 meters or more, and more preferably up to about 10 meters or more.
20 when transmitting to a small receiver/display unit 46, such as a palm-size, belt-worn receiver. The effective range is longer when transmitting to a unit with a better antenna, such as a bedside receiver. As described in detail below, suitable examples of receiver/display units 46, 48 include units that can be easily worn or carried or units that can be placed conveniently on, for example, a nightstand when the patient
25 is sleeping.

The transmitter 98 may send a variety of different signals to the receiver/display units 46, 48, typically, depending on the sophistication of the processing circuit 109. For example, the processing circuit 109 may simply provide raw signals, for example, currents from the working electrodes 58, without any
30 corrections for temperature or calibration, or the processing circuit 109 may provide converted signals which are obtained, for example, using a current-to-voltage converter 131 or 141 or a current-to-frequency converter. The raw measurements or

converted signals may then be processed by an analyzer 152 (see Figure 22) in the receiver/display units 46, 48 to determine the level of an analyte, optionally using temperature and calibration corrections. In another embodiment, the processing circuit 109 corrects the raw measurements using, for example, temperature and/or calibration information and then the transmitter 98 sends the corrected signal, and optionally, the temperature and/or calibration information, to the receiver/display units 46, 48. In yet another embodiment, the processing circuit 109 calculates the analyte level in the interstitial fluid and/or in the blood (based on the interstitial fluid level) and transmits that information to the one or more receiver/display units 46, 48, optionally with any of the raw data and/or calibration or temperature information. In a further embodiment, the processing circuit 109 calculates the analyte concentration, but the transmitter 98 transmits only the raw measurements, converted signals, and/or corrected signals.

One potential difficulty that may be experienced with the on-skin sensor control unit 44 is a change in the transmission frequency of the transmitter 98 over time. To overcome this potential difficulty, the transmitter may include optional circuitry that can return the frequency of the transmitter 98 to the desired frequency or frequency band. One example of suitable circuitry is illustrated in Figure 21 as a block diagram of an open loop modulation system 200. The open loop modulation system 200 includes a phase detector (PD) 210, a charge pump (CHGPMP) 212, a loop filter (L.F.) 214, a voltage controlled oscillator (VCO) 216, and a divide by M circuit (+M) 218 to form the phase-locked loop 220.

The analyte monitoring device 40 uses an open loop modulation system 200 for RF communication between the transmitter 98 and a receiver of, for example, the one or more receiver/display units 46, 48. This open loop modulation system 230 is designed to provide a high reliability RF link between a transmitter and its associated receiver. The system employs frequency modulation (FM), and locks the carrier center frequency using a conventional phase-locked loop (PLL) 220. In operation, the phase-locked loop 220 is opened prior to the modulation. During the modulation the phase-locked loop 220 remains open for as long as the center frequency of the transmitter is within the receiver's bandwidth. When the transmitter detects that the center frequency is going to move outside of the receiver

bandwidth, the receiver is signaled to stand by while the center frequency is captured. Subsequent to the capture, the transmission will resume. This cycle of capturing the center frequency, opening the phase-locked loop 220, modulation, and recapturing the center frequency will repeat for as many cycles as required.

5 The loop control 240 detects the lock condition of the phase-locked loop 220 and is responsible for closing and opening the phase-locked loop 220. The totalizer 250 in conjunction with the loop control 240, detects the status of the center frequency. The modulation control 230 is responsible for generating the modulating signal. A transmit amplifier 260 is provided to ensure adequate transmit signal
10 power. The reference frequency is generated from a very stable signal source (not shown), and is divided down by N through the divide by N block ($\div N$) 270. Data and control signals are received by the open loop modulation system 200 via the DATA BUS 280, and the CONTROL BUS 290.

 The operation of the open loop modulation system 200 begins with the
15 phase-locked loop 220 in closed condition. When the lock condition is detected by the loop control 240, the phase-locked loop 220 is opened and the modulation control 230 begins generating the modulating signal. The totalizer 250 monitors the VCO frequency (divided by M), for programmed intervals. The monitored frequency is compared to a threshold programmed in the totalizer 250. This
20 threshold corresponds to the 3dB cut off frequencies of the receiver's intermediate frequency stage. When the monitored frequency approaches the thresholds, the loop control 240 is notified and a stand-by code is transmitted to the receiver and the phase-locked loop 220 is closed.

 At this point the receiver is in the wait mode. The loop control 240 in the
25 transmitter closes the phase-locked loop 220. Then, modulation control 230 is taken off line, the monitored value of the totalizer 250 is reset, and the phase-locked loop 220 is locked. When the loop control 240 detects a lock condition, the loop control 240 opens the phase-locked loop 220, the modulation control 230 is brought on line and the data transmission to the receiver will resume until the center frequency of
30 the phase-locked loop 220 approaches the threshold values, at which point the cycle of transmitting the stand-by code begins. The $\div N$ 270 and $\div M$ 218 block set the frequency channel of the transmitter.

Accordingly, the open loop modulation system 200 provides a reliable low power FM data transmission for an analyte monitoring system. The open loop modulation system 200 provides a method of wide band frequency modulation, while the center frequency of the carrier is kept within receiver bandwidth. The effect of parasitic capacitors and inductors pulling the center frequency of the transmitter is corrected by the phase-locked loop 220. Further, the totalizer 250 and loop control 240 provide a new method of center frequency drift detection. Finally, the open loop modulation system 200 is easily implemented in CMOS process.

The rate at which the transmitter 98 transmits data may be the same rate at which the sensor circuit 97 obtains signals and/or the processing circuit 109 provides data or signals to the transmitter 98. Alternatively, the transmitter 98 may transmit data at a slower rate. In this case, the transmitter 98 may transmit more than one datapoint in each transmission. Alternatively, only one datapoint may be sent with each data transmission, the remaining data not being transmitted. Typically, data is transmitted to the receiver/display unit 46, 48 at least every hour, preferably, at least every fifteen minutes, more preferably, at least every five minutes, and most preferably, at least every one minute. However, other data transmission rates may be used. In some embodiments, the processing circuit 109 and/or transmitter 98 are configured to process and/or transmit data at a faster rate when a condition is indicated, for example, a low level or high level of analyte or impending low or high level of analyte. In these embodiments, the accelerated data transmission rate is typically at least every five minutes and preferably at least every minute.

In addition to a transmitter 98, an optional receiver 99 may be included in the on-skin sensor control unit 44. In some cases, the transmitter 98 is a transceiver, operating as both a transmitter and a receiver. The receiver 99 may be used to receive calibration data for the sensor 42. The calibration data may be used by the processing circuit 109 to correct signals from the sensor 42. This calibration data may be transmitted by the receiver/display unit 46, 48 or from some other source such as a control unit in a doctor's office. In addition, the optional receiver 99 may be used to receive a signal from the receiver/display units 46, 48, as described above, to direct the transmitter 98, for example, to change frequencies or frequency bands,

to activate or deactivate the optional alarm system 94 (as described below), and/or to direct the transmitter 98 to transmit at a higher rate.

Calibration data may be obtained in a variety of ways. For instance, the calibration data may simply be factory-determined calibration measurements which
5 can be input into the on-skin sensor control unit 44 using the receiver 99 or may alternatively be stored in a calibration data storage unit 100 within the on-skin sensor control unit 44 itself (in which case a receiver 99 may not be needed). The calibration data storage unit 100 may be, for example, a readable or readable/writeable memory circuit.

10 Alternative or additional calibration data may be provided based on tests performed by a doctor or some other professional or by the patient himself. For example, it is common for diabetic individuals to determine their own blood glucose concentration using commercially available testing kits. The results of this test is
15 input into the on-skin sensor control unit 44 either directly, if an appropriate input device (e.g., a keypad, an optical signal receiver, or a port for connection to a keypad or computer) is incorporated in the on-skin sensor control unit 44, or indirectly by inputting the calibration data into the receiver/display unit 46, 48 and transmitting the calibration data to the on-skin sensor control unit 44.

Other methods of independently determining analyte levels may also be used
20 to obtain calibration data. This type of calibration data may supplant or supplement factory-determined calibration values.

In some embodiments of the invention, calibration data may be required at periodic intervals, for example, every eight hours, once a day, or once a week, to confirm that accurate analyte levels are being reported. Calibration may also be
25 required each time a new sensor 42 is implanted or if the sensor exceeds a threshold minimum or maximum value or if the rate of change in the sensor signal exceeds a threshold value. In some cases, it may be necessary to wait a period of time after the implantation of the sensor 42 before calibrating to allow the sensor 42 to achieve equilibrium. In some embodiments, the sensor 42 is calibrated only after it has been
30 inserted. In other embodiments, no calibration of the sensor 42 is needed.

The on-skin sensor control unit 44 and/or a receiver/display unit 46, 48 may include an auditory or visual indicator that calibration data is needed, based, for

example, on a predetermined periodic time interval between calibrations or on the
implantation of a new sensor 42. The on-skin sensor control unit 44 and/or receiver
display/units 46, 48 may also include an auditory or visual indicator to remind the
patient that information, such as analyte levels, reported by the analyte monitoring
5 device 40, may not be accurate because a calibration of the sensor 42 has not been
performed within the predetermined periodic time interval and/or after implantation
of a new sensor 42.

The processing circuit 109 of the on-skin sensor control unit 44 and/or an
analyzer 152 of the receiver/display unit 46, 48 may determine when calibration data
10 is needed and if the calibration data is acceptable. The on-skin sensor control unit
44 may optionally be configured to not allow calibration or to reject a calibration
point if, for example, 1) a temperature reading from the temperature probe indicates
a temperature that is not within a predetermined acceptable range (e.g., 30 to 42 °C
or 32 to 40 °C) or that is changing rapidly (for example, 0.2 °C/minute, 0.5
15 °C/minute, or 0.7°C/minute or greater); 2) two or more working electrodes 58
provide uncalibrated signals that are not within a predetermined range (e.g., within
10% or 20%) of each other; 3) the rate of change of the uncalibrated signal is above
a threshold rate (e.g., 0.25 mg/dL per minute or 0.5 mg/dL per minute or greater); 4)
the uncalibrated signal exceeds a threshold maximum value (e.g., 5, 10, 20, or 40
20 nA) or is below a threshold minimum value (e.g., 0.05, 0.2, 0.5, or 1 nA); 5) the
calibrated signal exceeds a threshold maximum value (e.g., a signal corresponding to
an analyte concentration of 200 mg/dL, 250 mg/dL, or 300 mg/dL) or is below a
threshold minimum value (e.g., a signal corresponding to an analyte concentration of
50 mg/dL, 65 mg/dL, or 80 mg/dL); and/or 6) an insufficient amount of time has
25 elapsed since implantation (e.g., 10 minutes or less, 20 minutes or less, or 30
minutes or less).

The processing circuit 109 or an analyzer 152 may also request another
calibration point if the values determined using the sensor data before and after the
latest calibration disagree by more than a threshold amount, indicating that the
30 calibration may be incorrect or that the sensor characteristics have changed radically
between calibrations. This additional calibration point may indicate the source of
the difference.

The on-skin sensor control unit 44 may include an optional data storage unit 102 which may be used to hold data (e.g., measurements from the sensor or processed data) from the processing circuit 109 permanently or, more typically, temporarily. The data storage unit 102 may hold data so that the data can be used by the processing circuit 109 to analyze and/or predict trends in the analyte level, including, for example, the rate and/or acceleration of analyte level increase or decrease. The data storage unit 102 may also or alternatively be used to store data during periods in which a receiver/display unit 46, 48 is not within range. The data storage unit 102 may also be used to store data when the transmission rate of the data is slower than the acquisition rate of the data. For example, if the data acquisition rate is 10 points/min and the transmission is 2 transmissions/min, then one to five points of data could be sent in each transmission depending on the desired rate for processing datapoints. The data storage unit 102 typically includes a readable/writeable memory storage device and typically also includes the hardware and/or software to write to and/or read the memory storage device.

The on-skin sensor control unit 44 may include an optional alarm system 104 that, based on the data from the processing circuit 109, warns the patient of a potentially detrimental condition of the analyte. For example, if glucose is the analyte, then the on-skin sensor control unit 44 may include an alarm system 104 that warns the patient of conditions such as hypoglycemia, hyperglycemia, impending hypoglycemia, and/or impending hyperglycemia. The alarm system 104 is triggered when the data from the processing circuit 109 reaches or exceeds a threshold value. Examples of threshold values for blood glucose levels are about 60, 70, or 80 mg/dL for hypoglycemia; about 70, 80, or 90 mg/dL for impending hypoglycemia; about 130, 150, 175, 200, 225, 250, or 275 mg/dL for impending hyperglycemia; and about 150, 175, 200, 225, 250, 275, or 300 mg/dL for hyperglycemia. The actual threshold values that are designed into the alarm system 104 may correspond to interstitial fluid glucose concentrations or electrode measurements (e.g., current values or voltage values obtained by conversion of current measurements) that correlate to the above-mentioned blood glucose levels. The analyte monitor device may be configured so that the threshold levels for these

or any other conditions may be programmable by the patient and/or a medical professional.

A threshold value is exceeded if the datapoint has a value that is beyond the threshold value in a direction indicating a particular condition. For example, a
5 datapoint which correlates to a glucose level of 200 mg/dL exceeds a threshold value for hyperglycemia of 180 mg/dL, because the datapoint indicates that the patient has entered a hyperglycemic state. As another example, a datapoint which correlates to a glucose level of 65 mg/dL exceeds a threshold value for hypoglycemia of 70
10 mg/dL because the datapoint indicates that the patient is hypoglycemic as defined by the threshold value. However, a datapoint which correlates to a glucose level of 75 mg/dL would not exceed the same threshold value for hypoglycemia because the datapoint does not indicate that particular condition as defined by the chosen threshold value.

An alarm may also be activated if the sensor readings indicate a value that is
15 beyond a measurement range of the sensor 42. For glucose, the physiologically relevant measurement range is typically about 50 to 250 mg/dL, preferably about 40-300 mg/dL and ideally 30-400 mg/dL, of glucose in the interstitial fluid.

The alarm system 104 may also, or alternatively, be activated when the rate
20 of change or acceleration of the rate of change in analyte level increase or decrease reaches or exceeds a threshold rate or acceleration. For example, in the case of a subcutaneous glucose monitor, the alarm system might be activated if the rate of change in glucose concentration exceeds a threshold value which might indicate that a hyperglycemic or hypoglycemic condition is likely to occur.

The optional alarm system 104 may be configured to activate when a single
25 data point meets or exceeds a particular threshold value. Alternatively, the alarm may be activated only when a predetermined number of datapoints spanning a predetermined amount of time meet or exceed the threshold value. As another alternative, the alarm may be activated only when the datapoints spanning a predetermined amount of time have an average value which meets or exceeds the
30 threshold value. Each condition that can trigger an alarm may have a different alarm activation condition. In addition, the alarm activation condition may change depending on current conditions (e.g., an indication of impending hyperglycemia

may alter the number of datapoints or the amount of time that is tested to determine hyperglycemia).

The alarm system 104 may contain one or more individual alarms. Each of the alarms may be individually activated to indicate one or more conditions of the analyte. The alarms may be, for example, auditory or visual. Other sensory-stimulating alarm systems may be used including alarm systems which heat, cool, vibrate, or produce a mild electrical shock when activated. In some embodiments, the alarms are auditory with a different tone, note, or volume indicating different conditions. For example, a high note might indicate hyperglycemia and a low note might indicate hypoglycemia. Visual alarms may use a difference in color, brightness, or position on the on-skin sensor control device 44 to indicate different conditions. In some embodiments, an auditory alarm system is configured so that the volume of the alarm increases over time until the alarm is deactivated.

In some embodiments, the alarm may be automatically deactivated after a predetermined time period. In other embodiments, the alarm may be configured to deactivate when the data no longer indicate that the condition which triggered the alarm exists. In these embodiments, the alarm may be deactivated when a single data point indicates that the condition no longer exists or, alternatively, the alarm may be deactivated only after a predetermined number of datapoints or an average of datapoints obtained over a given period of time indicate that the condition no longer exists.

In some embodiments, the alarm may be deactivated manually by the patient or another person in addition to or as an alternative to automatic deactivation. In these embodiments, a switch 101 is provided which when activated turns off the alarm. The switch 101 may be operatively engaged (or disengaged depending on the configuration of the switch) by, for example, operating an actuator on the on-skin sensor control unit 44 or the receiver/display unit 46, 48. In some cases, an actuator may be provided on two or more units 44, 46, 48, any of which may be actuated to deactivate the alarm. If the switch 101 and or actuator is provided on the receiver/display unit 46, 48 then a signal may be transmitted from the receiver/display unit 46, 48 to the receiver 98 on the on-skin sensor control unit 44 to deactivate the alarm.

A variety of switches 101 may be used including, for example, a mechanical switch, a reed switch, a Hall effect switch, a Gigantic Magnetic Ratio (GMR) switch (the resistance of the GMR switch is magnetic field dependent) and the like.

Preferably, the actuator used to operatively engage (or disengage) the switch is placed on the on-skin sensor control unit 44 and configured so that no water can flow around the button and into the housing. One example of such a button is a flexible conducting strip that is completely covered by a flexible polymeric or plastic coating integral to the housing. In an open position the flexible conducting strip is bowed and bulges away from the housing. When depressed by the patient or another person, the flexible conducting strip is pushed directly toward a metal contact and completes the circuit to shut off the alarm.

For a reed or GMR switch, a piece of magnetic material, such as a permanent magnet or an electromagnet, in a flexible actuator that is bowed or bulges away from the housing 45 and the reed or GMR switch is used. The reed or GMR switch is activated (to deactivate the alarm) by depressing the flexible actuator bringing the magnetic material closer to the switch and causing an increase in the magnetic field within the switch.

In some embodiments of the invention, the analyte monitoring device 40 includes only an on-skin control unit 44 and a sensor 42. In these embodiments, the processing circuit 109 of the on-skin sensor control unit 44 is able to determine a level of the analyte and activate an alarm system 104 if the analyte level exceeds a threshold. The on-skin control unit 44, in these embodiments, has an alarm system 104 and may also include a display, such as those discussed below with respect to the receiver/display units 46, 48. Preferably, the display is an LCD or LED display. The on-skin control unit 44 may not have a transmitter, unless, for example, it is desirable to transmit data, for example, to a control unit in a doctor's office.

The on-skin sensor control unit 44 may also include a reference voltage generator 101 to provide an absolute voltage or current for use in comparison to voltages or currents obtained from or used with the sensor 42. An example of a suitable reference voltage generator is a band-gap reference voltage generator that uses, for example, a semiconductor material with a known band-gap. Preferably, the band-gap is temperature insensitive over the range of temperatures that the

semiconductor material will experience during operation. Suitable semiconductor materials includes gallium, silicon and silicates.

A bias current generator 105 may be provided to correctly bias solid-state electronic components. An oscillator 107 may be provided to produce a clock signal that is typically used with digital circuitry.

The on-skin sensor control unit 44 may also include a watchdog circuit 103 that tests the circuitry, particularly, any digital circuitry in the control unit 44 to determine if the circuitry is operating correctly. Non-limiting examples of watchdog circuit operations include: a) generation of a random number by the watchdog circuit, storage of the number in a memory location, writing the number to a register in the watchdog circuit, and recall of the number to compare for equality; b) checking the output of an analog circuit to determine if the output exceeds a predetermined dynamic range; c) checking the output of a timing circuit for a signal at an expected pulse interval. Other examples of functions of a watchdog circuit are known in the art. If the watchdog circuit detects an error that watchdog circuit may activate an alarm and/or shut down the device.

Receiver/Display Unit

One or more receiver/display units 46, 48 may be provided with the analyte monitoring device 40 for easy access to the data generated by the sensor 42 and may, in some embodiments, process the signals from the on-skin sensor control unit 44 to determine the concentration or level of analyte in the subcutaneous tissue. Small receiver/display units 46 may be carried by the patient. These units 46 may be palm-sized and/or may be adapted to fit on a belt or within a bag or purse that the patient carries. One embodiment of the small receiver/display unit 46 has the appearance of a pager, for example, so that the user is not identified as a person using a medical device. Such receiver/display units may optionally have one-way or two-way paging capabilities.

Large receiver/display units 48 may also be used. These larger units 48 may be designed to sit on a shelf or nightstand. The large receiver/display unit 48 may be used by parents to monitor their children while they sleep or to awaken patients during the night. In addition, the large receiver/display unit 48 may include a lamp,

clock, or radio for convenience and/or for activation as an alarm. One or both types of receiver/display units 46, 48 may be used.

The receiver/display units 46, 48, as illustrated in block form at Figure 22, typically include a receiver 150 to receive data from the on-skin sensor control unit 44, an analyzer 152 to evaluate the data, a display 154 to provide information to the patient, and an alarm system 156 to warn the patient when a condition arises. The receiver/display units 46, 48 may also optionally include a data storage device 158, a transmitter 160, and/or an input device 162. The receiver/display units 46, 48 may also include other components (not shown), such as a power supply (e.g., a battery and/or a power supply that can receive power from a wall outlet), a watchdog circuit, a bias current generator, and an oscillator. These additional components are similar to those described above for the on-skin sensor control unit 44.

In one embodiment, a receiver/display unit 48 is a bedside unit for use by a patient at home. The bedside unit includes a receiver and one or more optional items, including, for example, a clock, a lamp, an auditory alarm, a telephone connection, and a radio. The bedside unit also has a display, preferably, with large numbers and/or letters that can be read across a room. The unit may be operable by plugging into an outlet and may optionally have a battery as backup. Typically, the bedside unit has a better antenna than a small palm-size unit, so the bedside unit's reception range is longer.

When an alarm is indicated, the bedside unit may activate, for example, the auditory alarm, the radio, the lamp, and/or initiate a telephone call. The alarm may be more intense than the alarm of a small palm-size unit to, for example, awaken or stimulate a patient who may be asleep, lethargic, or confused. Moreover, a loud alarm may alert a parent monitoring a diabetic child at night.

The bedside unit may have its own data analyzer and data storage. The data may be communicated from the on-skin sensor unit or another receiver/display unit, such as a palm-size or small receiver/display unit. Thus, at least one unit has all the relevant data so that the data can be downloaded and analyzed without significant gaps.

Optionally, the bedside unit has an interface or cradle into which a small receiver/display unit may be placed. The bedside unit may be capable of utilizing

the data storage and analysis capabilities of the small receiver/display unit and/or receive data from the small receiver/display unit in this position. The bedside unit may also be capable of recharging a battery of the small receiver/display unit.

5 The receiver 150 typically is formed using known receiver and antenna circuitry and is often tuned or tunable to the frequency or frequency band of the transmitter 98 in the on-skin sensor control unit 44. Typically, the receiver 150 is capable of receiving signals from a distance greater than the transmitting distance of the transmitter 98. The small receiver/display unit 46 can typically receive a signal from an on-skin sensor control unit 44 that is up to 2 meters, preferably up to 5
10 meters, and more preferably up to 10 meters or more, away. A large receiver/display unit 48, such as a bedside unit, can typically receive a receive a signal from an on-skin sensor control unit 44 that is up to 5 meters distant, preferably up to 10 meters distant, and more preferably up to 20 meters distant or more.

In one embodiment, a repeater unit (not shown) is used to boost a signal from
15 an on-skin sensor control unit 44 so that the signal can be received by a receiver/display unit 46, 48 that may be distant from the on-skin sensor control unit 44. The repeater unit is typically independent of the on-skin sensor control unit 44, but, in some cases, the repeater unit may be configured to attach to the on-skin sensor control unit 44. Typically, the repeater unit includes a receiver for receiving
20 the signals from the on-skin sensor control unit 44 and a transmitter for transmitting the received signals. Often the transmitter of the repeater unit is more powerful than the transmitter of the on-skin sensor control unit, although this is not necessary. The repeater unit may be used, for example, in a child's bedroom for transmitting a signal from an on-skin sensor control unit on the child to a receiver/display unit in the
25 parent's bedroom for monitoring the child's analyte levels. Another exemplary use is in a hospital with a display/receiver unit at a nurse's station for monitoring on-skin sensor control unit(s) of patients.

The presence of other devices, including other on-skin sensor control units, may create noise or interference within the frequency band of the transmitter 98.
30 This may result in the generation of false data. To overcome this potential difficulty, the transmitter 98 may also transmit a code to indicate, for example, the beginning of a transmission and/or to identify, preferably using a unique identification code, the

particular on-skin sensor control unit 44 in the event that there is more than one on-skin sensor control unit 44 or other transmission source within range of the receiver/display unit 46, 48. The provision of an identification code with the data may reduce the likelihood that the receiver/display unit 46, 48 intercepts and
5 interprets signals from other transmission sources, as well as preventing "crosstalk" with different on-skin sensor control units 44. The identification code may be provided as a factory-set code stored in the sensor control unit 44. Alternatively, the identification code may be randomly generated by an appropriate circuit in the sensor control unit 44 or the receiver/display unit 46, 48 (and transmitted to the
10 sensor control unit 44) or the identification code may be selected by the patient and communicated to the sensor control unit 44 via a transmitter or an input device coupled to the sensor control unit 44.

Other methods may be used to eliminate "crosstalk" and to identify signals from the appropriate on-skin sensor control unit 44. In some embodiments, the
15 transmitter 98 may use encryption techniques to encrypt the datastream from the transmitter 98. The receiver/display unit 46, 48 contains the key to decipher the encrypted data signal. The receiver/display unit 46, 48 then determines when false signals or "crosstalk" signals are received by evaluation of the signal after it has been deciphered. For example, the analyzer 152 in the one or more receiver/display
20 units 46, 48 compares the data, such as current measurements or analyte levels, with expected measurements (e.g., an expected range of measurements corresponding to physiologically relevant analyte levels). Alternatively, an analyzer in the receiver/display units 46, 48 searches for an identification code in the decrypted data signal.

25 Another method to eliminate "crosstalk", which is typically used in conjunction with the identification code or encryption scheme, includes providing an optional mechanism in the on-skin sensor control unit 44 for changing transmission frequency or frequency bands upon determination that there is "crosstalk". This mechanism for changing the transmission frequency or frequency band may be
30 initiated by the receiver/display unit automatically, upon detection of the possibility of cross-talk or interference, and/or by a patient manually. For automatic initiation, the receiver/display unit 46, 48 transmits a signal to the optional receiver 99 on the

on-skin sensor control unit 44 to direct the transmitter 98 of the on-skin sensor control unit 44 to change frequency or frequency band.

Manual initiation of the change in frequency or frequency band may be accomplished using, for example, an actuator (not shown) on the receiver/display unit 46, 48 and/or on the on-skin sensor control unit 44 which a patient operates to
5 direct the transmitter 98 to change frequency or frequency band. The operation of a manually initiated change in transmission frequency or frequency band may include prompting the patient to initiate the change in frequency or frequency band by an audio or visual signal from the receiver/display unit 46, 48 and/or on-skin sensor
10 control unit 44.

Returning to the receiver 150, the data received by the receiver 150 is then sent to an analyzer 152. The analyzer 152 may have a variety of functions, similar to the processor circuit 109 of the on-skin sensor control unit 44, including 1) modifying the signals from the sensor 42 using calibration data and/or measurements
15 from the temperature probe 66, 2) determining a level of an analyte in the interstitial fluid, 3) determining a level of an analyte in the bloodstream based on the sensor measurements in the interstitial fluid, 4) determining if the level, rate of change, and/or acceleration in the rate of change of the analyte exceeds or meets one or more
20 threshold values, 5) activating an alarm system 156 and/or 94 if a threshold value is met or exceeded, 6) evaluating trends in the level of an analyte based on a series of sensor signals, 7) determine a dose of a medication, and 7) reduce noise or error contributions (e.g., through signal averaging or comparing readings from multiple
25 electrodes). The analyzer 152 may be simple and perform only one or a small number of these functions or the analyzer 152 may perform all or most of these functions.

The output from the analyzer 152 is typically provided to a display 154. A variety of displays 154 may be used including cathode ray tube displays (particularly for larger units), LED displays, or LCD displays. The display 154 may be monochromatic (e.g., black and white) or polychromatic (i.e., having a range of
30 colors). The display 154 may contain symbols or other indicators that are activated under certain conditions (e.g., a particular symbol may become visible on the display when a condition, such as hyperglycemia, is indicated by signals from the sensor.

42). The display 154 may also contain more complex structures, such as LCD or LED alphanumeric structures, portions of which can be activated to produce a letter, number, or symbol. For example, the display 154 may include region 164 to display numerically the level of the analyte, as illustrated in Figure 23. In one embodiment, the display 154 also provides a message to the patient to direct the patient in an action. Such messages may include, for example, "Eat Sugar", if the patient is hypoglycemic, or "Take Insulin", if the patient is hyperglycemic.

One example of a receiver/display unit 46, 48 is illustrated in Figure 23. The display 154 of this particular receiver/display unit 46, 48 includes a portion 164 which displays the level of the analyte, for example, the blood glucose concentration, as determined by the processing circuit 109 and/or the analyzer 152 using signals from the sensor 42. The display also includes various indicators 166 which may be activated under certain conditions. For example, the indicator 168 of a glucose monitoring device may be activated if the patient is hyperglycemic. Other indicators may be activated in the cases of hypoglycemia (170), impending hyperglycemia (172), impending hypoglycemia (174), a malfunction, an error condition, or when a calibration sample is needed (176). In some embodiments, color coded indicators may be used. Alternatively, the portion 164 which displays the blood glucose concentration may also include a composite indicator 180 (see Figure 24), portions of which may be appropriately activated to indicate any of the conditions described above.

The display 154 may also be capable of displaying a graph 178 of the analyte level over a period of time, as illustrated in Figure 24. Examples of other graphs that may be useful include graphs of the rate of change or acceleration in the rate of change of the analyte level over time. In some embodiments, the receiver/display unit is configured so that the patient may choose the particular display (e.g., blood glucose concentration or graph of concentration versus time) that the patient wishes to view. The patient may choose the desired display mode by pushing a button or the like, for example, on an optional input device 162.

The receiver/display units 46, 48 also typically include an alarm system 156. The options for configuration of the alarm system 156 are similar to those for the alarm system 104 of the on-skin sensor control unit 44. For example, if glucose is

the analyte, than the on-skin sensor control unit 44 may include an alarm system 156 that warns the patient of conditions such as hypoglycemia, hyperglycemia, impending hypoglycemia, and/or impending hyperglycemia. The alarm system 156 is triggered when the data from the analyzer 152 reaches or exceeds a threshold value. The threshold values may correspond to interstitial fluid glucose concentrations or sensor signals (e.g., current or converted voltage values) which correlate to the above-mentioned blood glucose levels.

The alarm system 156 may also, or alternatively, be activated when the rate or acceleration of an increase or decrease in analyte level reaches or exceeds a threshold value. For example, in the case of a subcutaneous glucose monitor, the alarm system 156 might be activated if the rate of change in glucose concentration exceeds a threshold value which might indicate that a hyperglycemic or hypoglycemic condition is likely to occur.

The alarm system 156 may be configured to activate when a single data point meets or exceeds a particular threshold value. Alternatively, the alarm may be activated only when a predetermined number of datapoints spanning a predetermined amount of time meet or exceed the threshold value. As another alternative, the alarm may be activated only when the datapoints spanning a predetermined amount of time have an average value which meets or exceeds the threshold value. Each condition that can trigger an alarm may have a different alarm activation condition. In addition, the alarm activation condition may change depending on current conditions (e.g., an indication of impending hyperglycemia may alter the number of datapoints or the amount of time that is tested to determine hyperglycemia).

The alarm system 156 may contain one or more individual alarms. Each of the alarms may be individually activated to indicate one or more conditions of the analyte. The alarms may be, for example, auditory or visual. Other sensory-stimulating alarm systems may be used including alarm systems 156 that direct the on-skin sensor control unit 44 to heat, cool, vibrate, or produce a mild electrical shock. In some embodiments, the alarms are auditory with a different tone, note, or volume indicating different conditions. For example, a high note might indicate hyperglycemia and a low note might indicate hypoglycemia. Visual alarms may

also use a difference in color or brightness to indicate different conditions. In some embodiments, an auditory alarm system might be configured so that the volume of the alarm increases over time until the alarm is deactivated.

In some embodiments, the alarms may be automatically deactivated after a predetermined time period. In other embodiments, the alarms may be configured to deactivate when the data no longer indicate that the condition which triggered the alarm exists. In these embodiments, the alarms may be deactivated when a single data point indicates that the condition no longer exists or, alternatively, the alarm may be deactivated only after a predetermined number of datapoints or an average of datapoints obtained over a given period of time indicate that the condition no longer exists.

In yet other embodiments, the alarm may be deactivated manually by the patient or another person in addition to or as an alternative to automatic deactivation. In these embodiments, a switch is provided which when activated turns off the alarm. The switch may be operatively engaged (or disengaged depending on the configuration of the switch) by, for example, pushing a button on the receiver/display unit 46, 48. One configuration of the alarm system 156 has automatic deactivation after a period of time for alarms that indicate an impending condition (e.g., impending hypoglycemia or hyperglycemia) and manual deactivation of alarms which indicate a current condition (e.g., hypoglycemia or hyperglycemia).

The receiver/display units 46, 48 may also include a number of optional items. One item is a data storage unit 158. The data storage unit 158 may be desirable to store data for use if the analyzer 152 is configured to determine trends in the analyte level. The data storage unit 158 may also be useful to store data that may be downloaded to another receiver/display unit, such as a large display unit 48. Alternatively, the data may be downloaded to a computer or other data storage device in a patient's home, at a doctor's office, etc. for evaluation of trends in analyte levels. A port (not shown) may be provided on the receiver/display unit 46, 48 through which the stored data may be transferred or the data may be transferred using an optional transmitter 160. The data storage unit 158 may also be activated to store data when a directed by the patient via, for example, the optional input device

162. The data storage unit 158 may also be configured to store data upon occurrence of a particular event, such as a hyperglycemic or hypoglycemic episode, exercise, eating, etc. The storage unit 158 may also store event markers with the data of the particular event. These event markers may be generated either automatically by the display/receiver unit 46, 48 or through input by the patient.

The receiver/display unit 46, 48 may also include an optional transmitter 160 which can be used to transmit 1) calibration information, 2) a signal to direct the transmitter 98 of the on-skin sensor control unit 44 to change transmission frequency or frequency bands, and/or 3) a signal to activate an alarm system 104 on the on-skin sensor control unit 44, all of which are described above. The transmitter 160 typically operates in a different frequency band than the transmitter 98 of the on-skin sensor control unit 44 to avoid cross-talk between the transmitters 98, 160. Methods may be used to reduce cross-talk and the reception of false signals, as described above in connection with the transmitter 100 of the on-skin sensor control unit 44.

In some embodiments, the transmitter 160 is only used to transmit signals to the sensor control unit 44 and has a range of less than one foot, and preferably less than six inches. This then requires the patient or another person to hold the receiver/display unit 46 near the sensor control unit 44 during transmission of data, for example, during the transmission of calibration information. Transmissions may also be performed using methods other than rf transmission, including optical or wire transmission.

In addition, in some embodiments of the invention, the transmitter 160 may be configured to transmit data to another receiver/display unit 46, 48 or some other receiver. For example, a small receiver/display unit 46 may transmit data to a large receiver/display unit 48, as illustrated in Figure 1. As another example, a receiver/display unit 46, 48 may transmit data to a computer in the patient's home or at a doctor's office. Moreover, the transmitter 160 or a separate transmitter may direct a transmission to another unit or to a telephone or other communications device that alerts a doctor or other individual when an alarm is activated and/or if, after a predetermined time period, an activated alarm has not been deactivated, suggesting that the patient may require assistance. In some embodiments, the receiver/display unit is capable of one-way or two-way paging and/or is coupled to a

telephone line to send and/or receive messages from another, such as a health professional monitoring the patient.

Another optional component for the receiver/display unit 46, 48 is an input device 162, such as a keypad or keyboard. The input device 162 may allow numeric or alphanumeric input. The input device 162 may also include buttons, keys, or the like which initiate functions of and/or provide input to the analyte monitoring device 40. Such functions may include initiating a data transfer, manually changing the transmission frequency or frequency band of the transmitter 98, deactivating an alarm system 104, 156, inputting calibration data, and/or indicating events to activate storage of data representative of the event.

Another embodiment of the input device 162 is a touch screen display. The touch screen display may be incorporated into the display 154 or may be a separate display. The touch screen display is activated when the patient touches the screen at a position indicated by a "soft button" which corresponds to a desired function. Touch screen displays are well known.

In addition, the analyte monitoring device 40 may include password protection to prevent the unauthorized transmission of data to a terminal or the unauthorized changing of settings for the device 40. A patient may be prompted by the display 154 to input the password using the input device 152 whenever a password-protected function is initiated.

Another function that may be activated by the input device 162 is a deactivation mode. The deactivation mode may indicate that the receiver/display unit 46, 48 should no longer display a portion or all of the data. In some embodiments, activation of the deactivation mode may even deactivate the alarm systems 104, 156. Preferably, the patient is prompted to confirm this particular action. During the deactivation mode, the processing circuit 109 and/or analyzer 152 may stop processing data or they may continue to process data and not report it for display and may optionally store the data for later retrieval.

Alternatively, a sleep mode may be entered if the input device 162 has not been activated for a predetermined period of time. This period of time may be adjustable by the patient or another individual. In this sleep mode, the processing circuit 109 and/or analyzer 152 typically continue to obtain measurements and

process data, however, the display is not activated. The sleep mode may be deactivated by actions, such as activating the input device 162. The current analyte reading or other desired information may then be displayed.

5 In one embodiment, a receiver/display unit 46 initiates an audible or visual alarm when the unit 46 has not received a transmission from the on-skin sensor control unit within a predetermined amount of time. The alarm typically continues until the patient responds and/or a transmission is received. This can, for example, remind a patient if the receiver/display unit 46 is inadvertently left behind.

10 In another embodiment, the receiver/display unit 46, 48 is integrated with a calibration unit (not shown). For example, the receiver/display unit 46, 48 may, for example, include a conventional blood glucose monitor. Another useful calibration device utilizing electrochemical detection of analyte concentration is described in U.S. Patent Application No. 08/795,767, incorporated herein by reference. Other devices may be used including those that operate using, for example,
15 electrochemical and colorimetric blood glucose assays, assays of interstitial or dermal fluid, and/or non-invasive optical assays. When a calibration of the implanted sensor is needed, the patient uses the integrated *in vitro* monitor to generate a reading. The reading may then, for example, automatically be sent by the transmitter 160 of the receiver/display unit 46, 48 to calibrate the sensor 42.

20

Integration with a Drug Administration System

Figure 25 illustrates a block diagram of a sensor-based drug delivery system 250 according to the present invention. The system may provide a drug to counteract the high or low level of the analyte in response to the signals from one or
25 more sensors 252. Alternatively, the system monitors the drug concentration to ensure that the drug remains within a desired therapeutic range. The drug delivery system includes one or more (and preferably two or more) subcutaneously implanted sensors 252, an on-skin sensor control unit 254, a receiver/display unit 256, a data storage and controller module 258, and a drug administration system 260. In some
30 cases, the receiver/display unit 256, data storage and controller module 258, and drug administration system 260 may be integrated in a single unit. The sensor-based drug delivery system 250 uses data from the one or more sensors 252 to provide

necessary input for a control algorithm/mechanism in the data storage and controller module 252 to adjust the administration of drugs. As an example, a glucose sensor could be used to control and adjust the administration of insulin.

5 In Figure 25, sensor 252 produces signals correlated to the level of the drug or analyte in the patient. The level of the analyte will depend on the amount of drug delivered by the drug administration system. A processor 262 in the on-skin sensor control unit 254, as illustrated in Figure 25, or in the receiver/display unit 256 determines the level of the analyte, and possibly other information, such as the rate or acceleration of the rate in the increase or decrease in analyte level. This
10 information is then transmitted to the data storage and controller module 252 using a transmitter 264 in the on-skin sensor control unit 254, as illustrated in Figure 25, or a non-integrated receiver/display unit 256.

If the drug delivery system 250 has two or more sensors 252, the data storage and controller module 258 may verify that the data from the two or more sensors
15 252 agrees within predetermined parameters before accepting the data as valid. This data may then be processed by the data storage and controller module 258, optionally with previously obtained data, to determine a drug administration protocol. The drug administration protocol is then executed using the drug administration system 260, which may be an internal or external infusion pump,
20 syringe injector, transdermal delivery system (e.g., a patch containing the drug placed on the skin), or inhalation system. Alternatively, the drug storage and controller module 258 may provide a the drug administration protocol so that the patient or another person may provide the drug to the patient according to the profile.

25 In one embodiment of the invention, the data storage and controller module 258 is trainable. For example, the data storage and controller module 258 may store glucose readings over a predetermined period of time, e.g., several weeks. When an episode of hypoglycemia or hyperglycemia is encountered, the relevant history leading to such event may be analyzed to determine any patterns which might
30 improve the system's ability to predict future episodes. Subsequent data might be compared to the known patterns to predict hypoglycemia or hyperglycemia and deliver the drug accordingly. In another embodiment, the analysis of trends is

performed by an external system or by the processing circuit 109 in the on-skin sensor control unit 254 or the analyzer 152 in the receiver/display unit 256 and the trends are incorporated in the data storage and controller 258.

5 In one embodiment, the data storage and controller module 258, processing circuit 109, and/or analyzer 152 utilizes patient-specific data from multiple episodes to predict a patient's response to future episodes. The multiple episodes used in the prediction are typically responses to a same or similar external or internal stimulus. Examples of stimuli include periods of hypoglycemia or hyperglycemia (or
10 corresponding conditions for analytes other than glucose), treatment of a condition, drug delivery (e.g., insulin for glucose), food intake, exercise, fasting, change in body temperature, elevated or lowered body temperature (e.g., fever), and diseases, viruses, infections, and the like. By analyzing multiple episodes, the data storage and controller module 258, processing circuit 109, and/or analyzer 152 can predict the course of a future episode and provide, for example, a drug administration
15 protocol or administer a drug based on this analysis. An input device (not shown) may be used by the patient or another person to indicate when a particular episode is occurring so that, for example, the data storage and controller module 258, processing circuit 109, and/or analyzer 152 can tag the data as resulting from a particular episode, for use in further analyses.

20 In addition, the drug delivery system 250 may be capable of providing on-going drug sensitivity feedback. For example, the data from the sensor 252 obtained during the administration of the drug by the drug administration system 260 may provide data about the individual patient's response to the drug which can then be used to modify the current drug administration protocol accordingly, both
25 immediately and in the future. An example of desirable data that can be extracted for each patient includes the patient's characteristic time constant for response to drug administration (e.g., how rapidly the glucose concentration falls when a known bolus of insulin is administered). Another example is the patient's response to administration of various amounts of a drug (e.g., a patient's drug sensitivity curve).
30 The same information may be stored by the drug storage and controller module and then used to determine trends in the patient's drug response, which may be used in

developing subsequent drug administration protocols, thereby personalizing the drug administration process for the needs of the patient.

Relationship of Subcutaneous and Blood Analyte Levels

5 It is often useful to determine analyte concentration in one fluid (e.g., blood) even though the measurements of analyte concentration are performed on another fluid (e.g., subcutaneous fluid). For example, it may be important to know blood glucose concentration for accurate diagnosis and/or insulin injections, or for comparison with other techniques, but it is more convenient and/or less painful or
10 intrusive to measure subcutaneous glucose concentrations. Sensor measurements made using subcutaneous fluid may be different from the desired quantity (e.g., blood glucose concentration) because of the existence of a mass transfer barrier, source and/or sink between compartment A, the region of measurement (e.g., the subcutaneous tissue), and compartment B, the region of interest (e.g., the blood).
15 For any such problem, one needs to develop a model that relates q_A , the measured quantity, to q_B , the desired quantity, using a system of equations: $q_A = \mathcal{L}q_B$. To solve for the desired quantity, the operator \mathcal{L} must be inverted. If the operator \mathcal{L} happens to be noninvertible or unstable to inversion, the use of such a model may be hindered.

20 One solution to this dilemma is the application of regularization techniques that, when used in conjunction with a model, can predict the desired quantity from the measured quantity. These methods often permit the imposition of a smoothing requirement that changes the operator \mathcal{L} , making it invertible. These regularization techniques can be used to infer one function from another measured function using a
25 postulated relationship between them.

With respect to subcutaneously implanted glucose sensors, the concentration of glucose in the blood is desired, especially for accurate dosing of insulin. There is typically a time lag between changes in glucose concentration of the blood and the subcutaneous tissue after, for example, an injection of insulin. To predict this time
30 lag and correlate the two concentrations, the glucose transport processes that mediate the transport of glucose from the blood to the subcutaneous tissue are investigated.

Three types of glucose transport processes exist: active transport, facilitated transport and passive transport. Active transport processes are present in the lumen of the small intestine and in the renal tubules, where glucose is transported against its concentration gradient, requiring energy. Facilitated transport processes include those in which, for example, carrier proteins, known as a glucose transporters, or GluTs, are present at a membrane surface to aid the diffusion of glucose across the membrane, as in adipocytes and in the blood-brain barrier. Finally, passive transport includes simple or Fickian diffusion which is typically driven by a concentration gradient and needs no special carrier proteins or energy.

10

Transfer of Glucose from Blood to Interstitial Fluid

A subcutaneously implanted sensor is placed in the interstitial fluid of the subcutaneous tissue. Typically, the important transport process are facilitated diffusion and a mass transfer resistance to transport of glucose between the blood and subcutaneous tissue. Thus, the relationship between the concentrations of glucose in the blood and subcutaneous tissues can be modeled by the mass transfer resistance from the blood to the subcutaneous region near the sensor and by the uptake of glucose by the surrounding subcutaneous tissue. Following a material balance, the rate of accumulation of glucose in the sensing volume V is given by the net rate of mass transfer of glucose into the region less the uptake of glucose by the surrounding cells via facilitated diffusion, which can be modeled using a reaction term. This relationship between the concentration of glucose in the subcutaneous tissue S and that in the blood B is given by,

15

20

$$V \frac{dS}{dt} = k_m A (B - S) - \frac{V k_r S}{K_m + S} \quad (1)$$

where A is the surface area of the region surrounding the sensor, k_m is a mass transfer coefficient, K_m is a Michaelis-Menten constant, and k_r is the reaction rate constant for uptake of glucose by the subcutaneous tissue. The mass transfer coefficient, Michaelis-Menten constant, and reaction rate constant for uptake of glucose by the subcutaneous tissue may be determined experimentally for a

25

particular animal, species, or as a generally applicable value. Alternatively, these values may be estimated.

The reaction rate constant may depend on the local insulin concentration I , as modeled, for example, by Yeh et al., *Biochem.* 34:523-531 (1995), incorporated by reference. However, for purposes of this discussion, the reaction rate constant is assumed to be constant. Appropriate changes in the equations below can be made if the reaction rate constant is dependent on the local insulin concentration.

Dividing equation (1) by the volume of the sensor region V yields:

$$\frac{dS}{dt} = \hat{\beta}(B - S) - \frac{k_r S}{K_m + S} \quad (2)$$

where $\hat{\beta} = k_m A/V$ and corresponds to the reciprocal of the time constant for mass transfer. It is convenient to non-dimensionalize the equation as follows, defining

$\bar{B} = \frac{B}{B_0}$, $\bar{S} = \frac{S}{B_0}$, $k_r = k_r' / (\hat{\beta} B_0)$ and $\bar{t} = \hat{\beta} t$, where B_0 can be an arbitrarily defined blood glucose concentration (e.g., a starting blood glucose concentration). Equation (2) then becomes

$$\frac{d\bar{S}}{d\bar{t}} = \bar{B} - \left[1 + \frac{k_r}{\frac{K_m}{B_0} + \bar{S}} \right] \bar{S} \quad (3)$$

The contents in brackets can be referred to as the pseudoconstant β . When there is no reaction, β is equal to 1; when there is a reaction, β is a weak function of \bar{S} , but \bar{S} typically does not change much. So, it can be assumed that β is constant over the time scale of the computation, letting \bar{S} be equal to the value at the center of the computation window. (The computation window is described following equation (7).) The nondimensional variables \bar{S} , \bar{B} and \bar{t} will continue to be referred to, but the overbars are removed for the remainder of this specification. The final equation,

$$\frac{dS}{dt} = B - \beta S, \quad (4)$$

determines the subcutaneous glucose concentration given the blood glucose concentration and can be termed a *forward* model.

Inversion of the Forward Model

5 The forward model is inverted to infer the blood glucose concentration given measured subcutaneous glucose concentrations. Predictions made from inversions may be highly sensitive to measurement errors and the inherent imperfections present in any mathematical model. Thus, regularization is often useful. If no regularization is used, the solution may be unstable and/or unreasonable.

10 As part of the regularization techniques, a smoothness condition may be imposed to minimize a function. The smoothness condition can include a combination of model fit and required smoothness. The minimization may result in a slightly modified set of equations which are well-conditioned (e.g., invertible and stable) and readily inverted and solved. Thus, rather than strictly forcing the data to
15 fit the model, the data is forced to be smooth (as defined by the regularization technique) and fit the model reasonably well. A set of equations is then derived that use the measured value of the subcutaneous concentration of glucose to predict the concentration of glucose in the blood.

20 To invert the forward model, it may be useful to rewrite the forward model in the form of a Volterra integral equation. To do so, both sides of equation (4) are multiplied by the function

$$\phi(t) = e^{\beta t} \quad (5a)$$

to yield

$$\frac{d}{dt} [\phi(t)S] = \phi(t)B. \quad (5b)$$

25 Recall that β is a pseudo-constant that is actually a mild function of S when reaction is present. Taking the definite integral of equation (5b) between times θ and t , and dividing both sides by $\phi(t)$ gives,

$$S(t) = S(\theta)e^{-\beta(t-\theta)} + \int_{\theta}^t B(\tau)e^{-\beta(t-\tau)} d\tau. \quad (6)$$

In the above equation, the variable θ is the initial time and t is the final time for the present window of computation. Integration can be done numerically using a finite difference scheme. $B(t)$ is computed for N times using a set of equations, or a single matrix-vector equation, with a time t represented on each of the N rows. As an approximation,

$$\int_{\theta}^t B(\tau)e^{-\beta(t-\tau)} d\tau = \sum_{i=1}^N B(t_i)e^{-\beta(t-t_i)} \Delta t \times W, \quad (7)$$

where N is the number of discretization points in the computation window and W is some weighting factor defined by a choice of quadrature scheme. For example, the integral in equation (7) is approximated by choosing weights that apply an extended Simpson's rule.

The time window contains N times at which subcutaneous measurements are taken, and which are separated by an interval Δt , so the size of the window is $(N-1)\Delta t$. The blood glucose concentration must be computed numerically, so B is discretized, i.e., represented by a piecewise constant over the window of computation. An advantage of computing the blood glucose value at the ending time of a window is that the method can be implemented continuously, updating the blood glucose concentration as more subcutaneous data become available. This allows the determination of blood glucose concentration from earlier measured analyte concentrations. This is in contrast to conventional analysis techniques that require measurements before and after the point in time at which the blood glucose concentration is determined.

In some instances this differential treatment may be sufficient. However, the solution to equation (6) may be sensitive to imperfections in the data and in the model, and its application alone may result in oscillatory predictions of the concentration of glucose in the blood, as shown in Figure 30.

Regularization techniques can be used to form a better behaved solution. The solution of the integral equation for $B(\tau)$ (or simply the vector b , which is the

vector of blood glucose values, b_i at the points in the present computation window) can be conditioned to be smooth in addition to closely satisfying equation (6) with experimental measurements of $S(t)$. For example, the functional $f[b]$,

$$f[b] = \chi^2[b] + \lambda\Psi[b], \quad (8)$$

5 can be minimized over any window of data points, where

$$\chi^2[b] = \sum_{\mu=1}^{i+N} \left(\int_{\theta}^{t_{\mu}} B(\tau) e^{-\beta(t_{\mu}-\tau)} d\tau - S(t_{\mu}) + S(\theta) e^{-\beta(t_{\mu}-\theta)} \right)^2. \quad (9)$$

The functional χ^2 represents the fit between the prediction of the model and the experimental data and the functional ψ indicates the smoothness of the prediction.

The λ variable is a weight which balances the amount of smoothing to data-
10 matching and can be constrained to range from 0 to ∞ . The functional ψ may be chosen based on an *a priori* belief about the quality of the output. If the output is likely to be constant over one window of computation, a first-order regularization, in which first derivatives are minimized over the window of interest, can be chosen, resulting in:

$$15 \quad \Psi[b] = \int_{\theta}^{t_{i+N}} [B'(\tau)]^2 d\tau \cong \sum_{\mu=1}^{i+N-1} [B(t_{\mu+1}) - B(t_{\mu})]^2 \Delta\tau. \quad (10)$$

The last term in equation (10) is a finite difference estimation of the integral where $\Delta\tau$ is the time difference between data points. If, instead, the solution is thought to be linear over one window of computation, and a second-order regularization can be imposed that will minimize second derivatives, resulting in:

$$20 \quad \Psi[b] = \int_{\theta}^{t_{i+N}} [B''(\tau)]^2 d\tau \cong \sum_{\mu=1}^{i+N-2} [-B(t_{\mu+2}) + 2B(t_{\mu+1}) - B(t_{\mu})]^2 \Delta\tau$$

(11)

Equation (8) above may be written in the following matrix form:

$$f = (A \cdot b - c)^2 + \lambda(b \cdot H \cdot b) \quad (12)$$

where

$$A_{j\mu} = \int_0^{t_\mu} e^{-\beta(t_\mu - \tau)} d\tau = \begin{cases} \frac{1}{2} e^{-\beta(t_\mu - t_\mu)} \Delta t & \mu = i \text{ or } j \\ e^{-\beta(t_\mu - t_\mu)} \Delta t & i < \mu < j, \\ 0 & j < \mu \end{cases} \quad (13)$$

and
$$c_\mu = S(t_\mu) - S(\theta) e^{-\beta(t_\mu - \theta)} \quad (14)$$

The definition for H stems from the choice of regularization such that first or the second derivatives over the window of computation are minimized. If a first-order regularization is chosen, the matrix H is given by,

$$H = \begin{bmatrix} 1 & -1 & 0 & 0 & 0 & \Lambda & 0 \\ -1 & 2 & -1 & 0 & 0 & \Lambda & 0 \\ 0 & -1 & 2 & -1 & 0 & \Lambda & 0 \\ M & & & O & & & M \\ 0 & \Lambda & 0 & -1 & 2 & -1 & 0 \\ 0 & \Lambda & 0 & 0 & -1 & 2 & -1 \\ 0 & \Lambda & 0 & 0 & 0 & -1 & 1 \end{bmatrix} \quad (15)$$

On the other hand, choosing a second-order regularization gives

$$H = \begin{bmatrix} 1 & -2 & 1 & 0 & 0 & 0 & 0 & \Lambda & 0 \\ -2 & 5 & -4 & 1 & 0 & 0 & 0 & \Lambda & 0 \\ 1 & -4 & 6 & -4 & 1 & 0 & 0 & \Lambda & 0 \\ 0 & 1 & -4 & 6 & -4 & 1 & 0 & \Lambda & 0 \\ M & & & & O & & & & M \\ 0 & \Lambda & 0 & 1 & -4 & 6 & -4 & 1 & 0 \\ 0 & \Lambda & 0 & 0 & 1 & -4 & 6 & -4 & 1 \\ 0 & \Lambda & 0 & 0 & 0 & 1 & -4 & 5 & -2 \\ 0 & \Lambda & 0 & 0 & 0 & 0 & 1 & -2 & 1 \end{bmatrix} \quad (16)$$

10 The matrix H that minimizes b, or implements a zeroth-order regularization, is given simply by the identity matrix.

Equation (12) is minimized by setting df/dB equal to 0, and, after some algebra, the blood glucose concentrations over the window of computation are given by,

$$(A^T \cdot A + \lambda H) \cdot b = A^T c. \quad (17)$$

The solution to the model was found at each time for which measurements were acquired in the experiment. We solve for **b** in equation (17) at each window of computation using known LU decomposition and back-substitution.

5 In another embodiment, the formulation may include a fixed initial condition. The functional to be minimized can be differentiated as before and the problem solved using identical methods. By enforcing the initial condition, the solution becomes a bit more unstable, because the initial condition that is being forced may not give the best fit. Other than causing more instability, this method
10 changes the prediction very little.

Besides assuring a relatively smooth solution for $B(\tau)$, the regularization techniques may be more desirable than the differential method for another reason. To use the differential method, the sensor data is often smoothed before processing, which could produce a lag in the results because backward smoothing would be
15 applied, since the application of real-time inversion dictates that the future data would be unknown. By using the regularization techniques, a relatively smooth solution can be obtained without creating this lag.

Processor

20 The determination of the blood glucose concentration from subcutaneous glucose concentration measurements can be performed by a processor (e.g., processing circuit 109 of Figure 18A or 18B or analyzer 152 of Figure 22), with or without a storage medium, in which the determination procedure is performed by software, hardware, or a combination thereof. According to another embodiment,
25 this same determination is accomplished using discrete or semi-programmable hardware configured, for example, using a hardware descriptive language, such as Verilog. In yet another embodiment, the determination may be performed using a processor having at least one look-up table arrangement with data stored therein to represent the complete result or partial results of the above equations based on a
30 given set of input data, the input data corresponding to parameters used on the right side of the equations.

EXAMPLES**Example 1**5 **Oral Glucose Tolerance Test Function**

In order to test the performance of the above inverse model under realistic conditions, a test function was used that resembles the typical human response to a substantial change in glucose intake or utilization. A simulation of a response to an oral glucose tolerance test (OGTT) and a simple fit of the human OGTT data presented by Jansson et al., *Am. J. Physiol.*, 225:E218-220 (1988), incorporated herein by reference, results in the following non-dimensional function:

$$B(t) = \frac{C}{B_0} (e^{-\gamma t} - e^{-\zeta t}) + 1, \quad (18)$$

where $\gamma = k_1 / \hat{\beta}$, $\zeta = k_2 / \hat{\beta}$, $k_1 = 0.054 \text{ min}^{-1}$, $k_2 = 0.021 \text{ min}^{-1}$, $C = 85.5 * [k_1 / (k_1 - k_2)]$ mg/dl, and $B_0 = 95 \text{ mg/dl}$. From previous comparisons with experimental data provided in Schmidtke et al., *Proc. of the Nat'l Acad. of Science*, 95, 294-299 (1998), incorporated herein by reference, $\hat{\beta}$ was chosen to be 0.05 min^{-1} . If no reaction is present, then the forward problem can be solved analytically, and the subcutaneous glucose concentration is given by:

$$S(t) = \frac{C}{B_0} \left[\frac{e^{-\gamma t}}{1-\gamma} - \frac{e^{-\zeta t}}{1-\zeta} \right] + 1. \quad (19)$$

20 Three cases of varying magnitudes of the reaction term were studied, including a) $k_r = 0$, b) $k_r = 1$ and $K_m = B_0$, and c) $k_r = 1$ and $K_m = B_0/3$. The functions $S(t)$ for the above three cases and their corresponding function $B(t)$ are plotted in Figure 31. The shapes of the input functions $S(t)$ are shifted down as the effective reaction rate constant, $\frac{k_r}{\frac{K_m}{B_0} + S}$, increases.

25 By varying the amount of noise on the input function, the performance of the inverse model for a wide range of λ (10^{-9} to 10^5) was analyzed for the three hypothetical cases. For the tests performed here, an error magnification factor, ϵ , as

a function of λ , and magnitude of reaction was computed. The error magnification factor was defined as:

$$\varepsilon = \frac{\% \text{ Output RMS Error}}{\% \text{ Input RMS Error}} \quad (20)$$

where

$$\% \text{ Output RMS Error} = \frac{\sqrt{\sum_i (\text{predicted}B_i - \text{true}B_i)^2}}{\sqrt{\sum_i \text{true}B_i^2}} \times 100\%, \quad (21)$$

and

$$\% \text{ Input RMS Error} = \frac{\sqrt{\sum_i (\text{noisy}S_i - \text{true}S_i)^2}}{\sqrt{\sum_i \text{true}S_i^2}} \times 100\%. \quad (22)$$

trueS are the input values that are free of generated noise and *trueB* are the values that would result from the equations if the *trueS* values were used as input.

10 The input function was modified by the addition of white noise or time-correlated noise. White noise was produced by first finding the average value of the input function over the test period. Then a random gaussian distribution was generated about that average with standard deviations of 0.5, 1, and 2% of that average:

$$15 \quad S_w(t) = S(t) + \text{Gauss}(\text{mean}, SD) \quad (23)$$

In the above equation, $S_w(t)$ is the new subcutaneous input function with white noise superimposed, where *Gauss* is a function of the mean,

$$\text{mean} = \frac{1}{n} \sum_{i=1}^n S(t_i) \quad (24)$$

and the standard deviation,

$$20 \quad SD = \frac{p}{n} \sum_{i=1}^n S(t_i) \quad (25)$$

Gauss is the function that generates the random Gaussian distribution with the given average and standard deviation. When *p* was set equal to 1%, an input function with 1% white noise resulted. This distribution was added to the OGTT function in equation (18) to produce the white noise input function.

Time-correlated noise was constructed via a simple moving average method, where the white noise input function produced above is averaged over a window of time that is of size m so that

$$S_c(t_{i+m}) = \frac{1}{m} \sum_{j=0.1.2...}^m S_w(t_{i+j}). \quad (26)$$

5 where $S_c(t)$ is the input function with superimposed time-correlated noise. In other words, the input function with white noise was averaged over the i th window of time to give the new function's value at the ending time of the window. The nondimensional time window over which the values were averaged was 1/100th of the total time of the test. The input functions with these two types of noise are
10 illustrated in Figure 32 with RMS errors of 1%.

Example 2

Order of Regularization and Estimation of N and Δt

A comparison of first- and second-order regularization methods for the case
15 of no reaction (case a) and 1% white noise on the input is shown in Figure 33. The data in Figure 33 were obtained using a window size of 10 data points ($N=10$), which corresponds to 1/50th of the total test time, and the Δt was 0.0185. The error magnification factor versus weighting factor curves for the above cases and for the zeroth-order regularization are in Figure 34.

20 For the three levels of white noise superimposed on the synthetic subcutaneous glucose measurements, and for this window size, the first-order regularization method predicted the blood glucose concentration better than either the zeroth- or second-order regularization. The lowest ϵ for the zeroth-, first-, and second-order regularizations were 63, 7, and 13 respectively. Typically, first-
25 order regularization is the preferred method for most problems, unless one expects a constant profile, in which zeroth-order regularization would be the natural choice.

Figure 35 shows the error magnification factor versus the regularization parameter for a variety of sizes of computation windows, and also for several sampling rates, where the sampling rate is defined as Δt^{-1} . The computation
30 window size and sample rate had a strong effect on the lowest ϵ achievable using the inverse method. A decrease in the sampling rate, as expected, causes the error magnification factor to increase, so samples should be taken as often as possible. However, increasing the sampling rate causes the condition number of the matrix, $A^T \cdot A + \lambda H$, to increase, increasing the error.

As the sampling time between the measurements is increased, the error magnification factor increases. Similarly, as the window size grows, the error factor decreases. Window size is equal to $(N-1)\Delta t$, where N is the number of data points in the window, and Δt is the time between the data points. Keeping the sampling rate constant, Figure 35 shows how ϵ changes as the window size increases from $N=10$ to $N=160$. When N is increased from 10 to 20, the decrease in ϵ is larger than when N is increased from 40 to 80. The reason for this is that, as the size of the window gets larger, the trailing values of measurements will have less of an effect on the solution, since the kernel is exponential in time (see equation 14). Finally, when N increases from 80 to 160, there is no substantial decrease in ϵ . A reason for this could be that the window size has grown so much that the first order derivatives can no longer be minimized and expect a good *a priori* estimate of the behavior of the solution. That is, the window size is now on order of the time constant of the mass transfer coefficient. Also, as expected, there is never an ϵ below 1, because the output function will always have at least as much error as the input function. Note that for the improvement on ϵ by increasing N from 10 to 80, the computation time expense also increases. Keeping the sampling rate constant, an optimal window size was found for this particular problem which was 8 times larger than the one used above. Application of this size of computation window yielded an error magnification factor of 1.6, and required a regularization factor λ of 3.

With the larger, optimal window size, the regularization methods were reexamined. Both first- and second-order regularizations give good inverses, with an error magnification factor (ϵ) of about 1.5 for each case, as shown in Figure 36. Note that a much larger regularization parameter is required for the second-order than for the first-order method. The regularization parameter typically indicates the relative amount of model matching to smoothing imposed. Either of these methods could be used for the remainder of the analysis.

Example 3

White Noise vs. Correlated Noise

In general, the method of regularization and inversion gave similar results for both white noise and correlated noise on the subcutaneous data. The data with correlated noise and the data with white noise superimposed required similar weighting factors to give similar values of ϵ . The correlated noise was smoother than the white noise, but with larger error magnification factors than for white noise. In fact, the correlated noise causes the model to deviate from the true function for longer sustained times, so the larger error magnification factors are not unexpected.

Figure 37 illustrates the $\epsilon(\lambda)$ curves for white and correlated noise in the case of 1% RMS Input Error and reaction case a. Both functions find their minimum at similar values of λ , at about 3.0 and 6.0 for white noise and correlated noise, respectively. Overall, the curves go to infinity as λ approaches zero, which indicates that a regularization is necessary due to the instability of the inverse problem. Also, the curves plateau as λ increases beyond order 1, which shows us that the regularization only causes more and more damping of the solution as λ increases, causing there to be a maximum finite difference between the prediction and the true solution (i.e., the solution goes to a constant about the initial point of the prediction).

The error magnification factor, ϵ , decreased as the input error increased for both sets of data. Tables 1 and 2 contain the results.

Table 1
White noise, first-order regularization results.

Reaction Case	Input RMS Error	Output RMS Error	Best λ	ϵ
$k_r = 0$	0.5	1.16	0.9	2.32
$k_r = 0$	1.0	1.58	3.0	1.58
$k_r = 0$	2.0	2.17	6.0	1.09
$k_r = 1, K_m = B_0/3$	0.5	1.31	0.7	2.62
$k_r = 1, K_m = B_0/3$	1.0	1.65	2.0	1.65
$k_r = 1, K_m = B_0/3$	2.0	2.15	5.0	1.07
$k_r = 1, K_m = B_0$	0.5	1.04	0.8	2.08
$k_r = 1, K_m = B_0$	1.0	1.31	2.0	1.31
$k_r = 1, K_m = B_0$	2.0	1.75	4.0	0.88

Table 2
Time-correlated noise using simple moving average method,
first-order regularization results.

Reaction Case	Input RMS Error	Output RMS Error	Best λ	ϵ
$k_r = 0$	0.32	1.20	0.6	3.75
$k_r = 0$	0.53	1.63	2.0	3.08
$k_r = 0$	1.00	2.21	6.0	2.21
$k_r = 1, K_m = B_0/3$	0.32	1.24	0.5	3.88
$k_r = 1, K_m = B_0/3$	0.53	1.61	1.0	3.04
$k_r = 1, K_m = B_0/3$	1.00	2.13	4.0	2.13
$k_r = 1, K_m = B_0$	0.32	0.84	0.6	2.63
$k_r = 1, K_m = B_0$	0.53	1.18	1.0	2.23
$k_r = 1, K_m = B_0$	1.00	1.66	3.0	1.66

5

Example 4

Estimation of Weighting Factor

Many workers have proposed methods for estimating the best value for the weighting or regularization factor, λ , including Beck et al., Inverse Heat Conduction, John Wiley & Sons, New York (1985); Graham, *Bell Systems Tech. J.*, 62:101-110 (1983); Press et al., Numerical Recipes in Fortran - 2nd Ed., Cambridge University Press (1992); and Reinsch, *Numerische Mathematik*, 10:177-183 (1967), all of which are incorporated herein by reference. As recommended in Press et al., the weight factor λ may be roughly estimated, at first, by implementing the equation,

15

$$\lambda = \text{Tr}(R^T \cdot R) / \text{Tr}(H) \quad (27a)$$

where

$$R = A/\sigma \quad (27b)$$

and σ is the standard deviation of the measurements. This estimate of λ allow for approximately equal amounts of model matching and smoothness. Another interpretation of the conditions is that the data are required to fit the model only within the measurement error.

The regularization parameter may also depend on the number of measurements available, n , in addition to the standard deviation of those measurements. Thus, the following condition on the residual sum of the squares, \mathfrak{R} , can be applied to find an appropriate λ :

25

$$\mathfrak{R} = (A \cdot b - c)^T (A \cdot b - c) \quad (28)$$

and require
$$\left[n - (2n)^{1/2} \right] \sigma^2 < \mathfrak{R} < \left[n + (2n)^{1/2} \right] \sigma^2. \quad (29)$$

Criterion 1 can be defined as $\mathfrak{R} = n\sigma^2$. This method can be referred to as the discrepancy criterion.

Alternatively, λ can be selected using the concept of the minimum squared error, as described in Beck et al., Inverse Heat Conduction, John Wiley & Sons (1985), incorporated herein by reference. This can be called criterion 2. The parameter λ will often have an optimal value that remains approximately constant when the integration time interval and sampling rate is constant, so this process of determining λ may only be necessary once for a given set of parameters.

Comparison of the two results, \mathfrak{R} values are obtained within the designated range, as shown in Figure 38. The application of criterion 1 gives ϵ equal to 2.5 ($\lambda=0.5$) which is very close to the criterion 2 result of $\epsilon=2.32$ ($\lambda=1.0$). The largest output error that would occur by choosing λ such that \mathfrak{R} is within the above bounds is 4.5% ($\epsilon=9.0$) for the case of no reaction and 0.5% RMS error in the input in the form of white noise. Choosing \mathfrak{R} equal to $n\sigma^2$ gives ϵ equal to 2.5. Thus, the criterion 2 result can often be approximated by applying criterion 1 provided an estimate of σ is available.

With regard to the method of choosing the regularization factor above, as the window size increased, so did the regularization factor that gave the minimum ϵ . The increase in window size effectively increases the number of measurements available to calculate a given $B(t)$. Typically, the best λ was directly proportional to N until the window became too large to expect a good *a priori* estimate of the function behavior from first-order regularization.

25

Example 5

Effect of Nonlinearity

Figure 39 illustrates the error magnification factor versus weighting factor for reaction cases a and c when the input contains 1% white noise. For a given input RMS error, the required weighting factor remained constant as K_m increased, but the output RMS error decreased as K_m increased. Therefore, if the reaction term is found to be important in the modeling of the lag between the blood glucose and subcutaneous tissue glucose in humans, the inversion will not suffer. Instead, the results are better, relative to the input error, in the presence of a reaction term than

30

they are with no reaction at all. The reaction term acts as a damping term in the forward model. In other words, the term in the forward model that de-stabilizes the inversion is the derivative of the subcutaneous glucose concentration with respect to time, while the reaction term tends to stabilize the inversion.

5

Example 6

Preparation of Glucose Electrodes

Glucose electrodes were structurally similar to those described in Csoregi et al., *Anal. Chem.*, 67:1240-1244 (1995), incorporated herein by reference. A 0.25 mm gold wire with a 0.04 mm Teflon coating. A 0.09 mm portion of the gold at the end of the wire was removed, leaving a narrow tube of Teflon. A "wired" glucose oxidase transduction layer was formed by depositing a solution of 10 mg/mL of {poly[(1-vinylimidazolyl) osmium (4,4'-dimethylbipyridine)₂Cl]}⁺²⁺, 10 mg/mL glucose oxidase (in HEPES 10 mM at pH 8.1), and 2.5 mg/mL poly(ethylene glycol) mixed in a 78:16:6 wt.% ratio. The solution was deposited in the Teflon tube to coat the exposed surface of the gold wire. The electrodes were then rinsed five times and cured at 45 °C for 15 minutes. A glucose flux restricting layer was formed by sequentially filling the 0.09 mm deep, 250 μm diameter recess and curing (at room temperature for 20 min) twice with a 1% solution of cellulose acetate in cyclohexanone; once with a 0.5% solution of Nafion (Aldrich, Milwaukee, WI) in n-propanol; and once with a freshly prepared solution of poly(vinyl pyridine) acetate (PVPA) (25 mg/mL in water) and polyfunctional aziridine (PAZ) (XAMA-7, E.I.T. Inc., Lakewilie, SC) (30 mg/mL in water) in a 1:2 volume ratio, this layer being cured for at least 8 hr. A biocompatible layer was then formed of a sensitized 10 wt.% aqueous tetraacrylated poly(ethylene oxide) solution by photo-cross-linking (45 sec. UV exposure).

The in vitro response time of the glucose electrodes was measured for both increasing and decreasing step changes in glucose concentration prior to implantation. The measurements were made at 37 ± 0.5°C in a rapidly stirred, jacketed electrochemical cell containing pH 7.4 phosphate buffered saline (PBS). The three-electrode cell had a saturated calomel reference electrode (SCE), a platinum counter electrode, and the glucose electrode and was poised at 200 mV vs. SCE. Step changes increasing the glucose concentration (90 mg/dL to 180 mg/dL) were made by injecting into the rapidly stirred solution an aliquot of concentrated

aqueous glucose (2M). Step changes decreasing the glucose concentration (180 mg/dL to 90 mg/dL) were made by injecting PBS into the cell.

The intrinsic response times to increasing and decreasing step changes in glucose concentration were 2.59 ± 1.17 min and 1.55 ± 0.79 min (n=14) respectively.

Example 7

In vivo experiments

Male Sprague-Dawley rats, 380-520 g, were preanesthetized with halothane (Halocarbon Laboratories, North Augusta, SC) and anesthetized by intraperitoneal injection (0.3 ml) of an equal volume mixture of acepromazine maleate (10 mg/ml), ketamine (100 mg/ml) and xylazine (20 mg/ml). The animals were then shaven about the neck, the abdomen, and the area between the scapulae, then secured on a homeothermic blanket system (Harvard Apparatus, South Natick MA). First the right external jugular vein was located and cleared of extraneous tissue. The distal side of the right vein was tied off with 4-0 silk, and a small cut was made in the vein. A 0.0375" diameter medical-grade silastic tube was inserted into the proximal portion of the right jugular vein and secured with 4-0 silk. A dose of 100 U/kg body wt of heparin solution was then administered, followed by an equal volume of saline, to clear the line. Next, the rat's skin was sutured closed. The rat was then rolled onto its abdomen, while assuring that the line in the jugular vein was not pulled out, and an electrode was inserted in the subcutaneous tissue between the scapulae of the animal using a 22-gauge introducing catheter needle (PER-Q-Cath, Gesco, San Antonio, TX). The animal was then returned to its back and resecured. The left external jugular vein was then located and cleared of extraneous tissue. Next, the distal side of the left jugular vein was tied off and a small cut was made in the vein. A silastic tube of 1.5 cm length was inserted into the proximal side as a guide, and a glucose electrode was inserted inside the guide tube. The tube and the sensor were secured with 4-0 silk, with the electrode's insulating gold wire protruding beyond the end of the guide tube. The incision site was then moistened and packed with gauze. An ion-conducting gel was then applied to a skin reference (Ag/AgCl) electrode, and the electrode was placed on the rat's abdomen. The implanted electrodes as well as the reference electrode were connected to a biopotentiostat (13), the output of which was logged with a data logger.

After the output of the implanted electrodes reached a stable baseline (0.5–1 hr), an intravenous injection of 0.5 U/kg of regular insulin (RU-100, Eli Lilly, Indianapolis, IN) was administered through the right jugular vein. Blood samples were collected at $t = -20, -10, -1, 3, 6, 9, 12, 15, 20, 25, 30, 35, 40, 45, 60, 75, 90$ min after the insulin injection. The whole blood samples were obtained from the left jugular vein and were immediately placed in tubes containing heparin and sodium fluoride and kept on ice until analysis. All blood samples were analyzed in duplicate using a YSI Model 2300 glucose analyzer (YSI, Yellow Springs, OH). At time $t=0$, the insulin dose was injected through the infusion catheter and cleared with heparinized saline. At the end of the experiment the rat was euthanized by sodium pentobarbital injection i.p. or asphyxiation by CO_2 , consistent with the recommendations of the panel on Euthanasia of the American Veterinary Association. All in vivo experimentation was approved by the University of Texas Institutional Animal Use and Care Committee.

The implanted electrodes were sufficiently glucose selective to be calibrated by withdrawal of a single sample of blood and assay of its glucose concentration ("one-point in vivo calibration"). After the current output of the sensor stabilized, 20–40 min after implantation and electrical connection to the bipotentiostat, a single sample of blood was drawn and its glucose concentration was assayed using the YSI glucose analyzer. From this measurement, a current to glucose concentration conversion factor (mg/dl per nA) was calculated for the implanted electrodes. This factor was used to obtain all glucose estimates for the remainder of the test period.

Example 8

Data Analysis

The onset of the decline in the concentrations of venous and subcutaneous glucose following the injection of insulin were determined graphically using the time-concentration plots and a method used in process control to calculate time delays (14). The tangent line at the point of inflection was drawn (see Figure 40) and the line, tracking the basal concentration of glucose prior to the injection of insulin, was extended. The intersection of the two lines defined the onset point of the decline. The onset times were referenced to the time at which insulin was injected. The rate of decline in glucose concentration in the period between 6 and 20 minutes after insulin injection was calculated by linear regression analyses for the periodically sampled blood from the vein where insulin was injected; the

contralateral jugular vein, where an electrode was implanted; and for the subcutaneous interstitial fluid, where the second electrode was implanted. The values are presented as means \pm std, along with their statistical significance, assessed when appropriate by a Student's *t*-test for paired data, with $p < 0.05$ considered as statistically significant.

Figure 41 shows the typical output of the subcutaneous (dotted line) and jugular vein (solid line) electrodes during an *in vivo* experiment. Following insulin injection, the average venous blood glucose concentrations of the rats ($n=7$) decreased from 207 ± 67 mg/dl to 59 ± 12 mg/dl. The minimum in blood glucose concentration was reached 36.6 ± 7.2 minutes after the injection of insulin. Table 3 lists the average lag times between the lowest subcutaneous sensor readings and the point of lowest glucose concentration in the concentrations in the blood withdrawn from the vein where the insulin was injected, and also between the lowest readings by the sensor implanted in the contralateral jugular vein and the samples withdrawn from the injected jugular vein.

Table 3
Declining glucose characteristics.

Location	Onset time (min)	Decline rate (mg dl ⁻¹ • min ⁻¹)	t _{minimum glucose} (min)	Lag time (min)
Blood samples	3.3 \pm 0.5	6.8 \pm 2.0	36.6 \pm 7.2	—
Intravenous sensor	5.6 \pm 1.7	7.0 \pm 2.5	40.3 \pm 5.9	3.7 \pm 4.3
Subcutaneous sensor	8.9 \pm 2.1	3.9 \pm 1.3	61.2 \pm 7.5	24.5 \pm 6.8

The onsets of the decline with respect to the time of injection of insulin, measured in the injected jugular vein, the contralateral jugular vein and the subcutaneous fluid are also shown in Table 3, along with the rates of decline in the period between 6 and 20 min after insulin injection. Figure 42 shows the average difference between the estimates of the subcutaneous glucose concentrations and the actual blood glucose concentrations as a function of time.

The nadir in subcutaneous glucose was statistically different from the nadir in blood glucose ($p < 0.001$) and occurred 24.5 ± 6.8 minutes later. Similarly, the onset of declining subcutaneous glucose levels (8.9 ± 2.1 min after insulin injection) was statistically different ($p < 0.001$) from the onset in blood glucose levels 0.5 min after insulin injection). The rate of drop in glucose levels, between 6–20 minutes

after insulin injection, was slower in the subcutaneous fluid ($3.9 \pm 1.3 \text{ mg dl}^{-1} \text{ min}^{-1}$), than in blood ($6.8 \pm 2.0 \text{ mg dl}^{-1} \text{ min}^{-1}$, $p = 0.003$).

In the contralateral jugular vein, the minimal glucose concentration was reached 3.7 minutes after it was reached in the injected vein (36.6 vs. 40.3 min., $p = 0.06$). The rates of decline during the 6 to 20 minute period were nearly identical in the two opposite jugular veins (6.8 and 7.0 $\text{mg dl}^{-1} \text{ min}^{-1}$, $p = 0.59$). The onsets of the decline in glucose concentrations were statistically different for the opposite veins (3.3 vs. 5.6 min, $p = 0.01$).

10

Example 9

Prediction of Subcutaneous Glucose Concentration

A typical plot of a prediction of the subcutaneous concentration of glucose given the concentration of glucose in the blood from the jugular sensor is shown in Figure 43, where the only fitted parameter was $\beta = 0.04 \text{ min}^{-1}$. The uptake term of the model was found to be negligible for most of the data sets and was set to zero for all sets. This finding is not surprising, because the sensor was placed between the connective tissue and smooth muscle tissue where the rate of glucose uptake is low compared to the rate of uptake in adipose tissue or skeletal muscle.

The values of β were determined by a least squares minimization of the average error for each individual data set and ranged from 0.04 to 0.11 min^{-1} , except for one case, where β equaled 0.22 min^{-1} . These results in rats show that β is relatively constant. If this proves to be true also in humans then it may not be necessary to determine β for each patient, or for different subcutaneous placement sites in a particular patient. Table 4 summarizes the statistics for comparison of the prediction of the forward model with the subcutaneous sensor data.

25

Table 4
Average differences between the measured subcutaneous glucose concentrations and the predicted subcutaneous glucose concentrations.

Rat	Forward Model	No Model
1	12.4%	23.8%
2	14.6%	23.5%
3	11.9%	16.2%
4	7.4%	24.1%
5	6.0%	16.0%
6	4.9%	14.3%
7	5.2%	9.6%
Mean	8.9%	18.2%
std	7.8%	14.5%

- 5 On average the forward model predicted the readings of the subcutaneous sensor from those in blood with a difference of $8.9 \pm 7.8\%$. If the subcutaneous concentration of glucose were estimated to equal that measured by the jugular sensor (*i.e.*, if the model were not used), the average difference would have been $18.2 \pm 14.5\%$. The values derived through the model and those measured differed and the
- 10 difference was statistically significant ($p=0.001$). In the 40-min interval after injection of the insulin, the time period that is most in need of correction, the average of the maximal differences was decreased through the model from 30.7% to 11.1% (Table 5, $p = 0.01$).

Table 5
Maximum differences between the measured subcutaneous glucose concentrations and the predicted subcutaneous glucose concentrations during the 40 minute period following insulin injection.

Rat	Forward Model	No Model
1	12.5%	22.9%
2	15.9%	34.8%
3	17.7%	21.6%
4	2.7%	50.4%
5	13.9%	35.3%
6	9.7%	35.8%
7	5.2%	14.2%
Mean	11.1%	30.7%
Std	5.5%	12.0%

5

Example 10

Prediction of Blood Glucose Concentration

The value of $B(\tau)$ in equations (6-8) was determined as described above.

The weight factor λ was first estimated by the method described above. The initial condition of $B(0)=S(0)$ was then enforced within 10% to find a more exact value of λ based on the initial guess. Further refining of the value of λ had little effect on the results. Time $t=0$ for modeling purposes was taken to be 20 minutes before insulin injection. Plots of the inverse model predictions are shown in Figure 44.

On average, the inverse model predicted in all experiments the performance of blood glucose concentrations sensed in the jugular veins, even when the blood and subcutaneous glucose concentrations were dropping rapidly and from a steady state, within $11.1 \pm 10.6\%$, as shown in Table 6. If the subcutaneous concentration of glucose were considered to equal that given by the jugular sensor (i.e., if the inverse model were not used), the average difference would have been greater $22.9 \pm 14.4\%$ ($p=0.025$).

20

Table 6
Average differences between the measured blood glucose concentrations and
the blood glucose concentrations predicted from the subcutaneous
measurements.

Rat	Inverse Model	No Model
1	13.3%	22.7%
2	13.3%	20.5%
3	13.6%	15.9%
4	14.8%	48.9%
5	8.2%	23.2%
6	7.9%	15.7%
7	6.9%	13.7%
Mean	11.1%	22.9%
Std	10.6%	14.4%

5

Furthermore, during the 40 minute period following insulin injection, when the dynamic difference was greatest, the maximum difference between the blood and the subcutaneous glucose concentrations was $84.1 \pm 36.1\%$. By using the inverse model the maximum difference between the computed blood glucose concentration and the actual concentration was reduced to $29.3 \pm 8.4\%$ (Table 7, $p=0.006$).

10

Table 7

Maximum differences between the measured blood glucose concentrations and the blood glucose concentrations predicted from the subcutaneous measurements during the 40 minute period following insulin injection.

Rat	Inverse Model	No Model
1	22.8%	72.8%
2	38.8%	67.8%
3	18.0%	41.3%
4	31.5%	157.3%
5	28.5%	94.9%
6	40.9%	72.7%
7	24.8%	82.1%
Mean	29.3%	84.1%
Std	8.4%	36.1%

5

The present invention should not be considered limited to the particular examples described above, but rather should be understood to cover all aspects of the invention as fairly set out in the attached claims. Various modifications, equivalent processes, as well as numerous structures to which the present invention may be applicable will be readily apparent to those of skill in the art to which the present invention is directed upon review of the instant specification. The claims are intended to cover such modifications and devices.

10

WE CLAIM:

1. A method for determining analyte concentration in blood, comprising:
- 5 determining a subcutaneous analyte concentration from a subcutaneous region using a sensing device;
- determining an analyte concentration in blood from the subcutaneous analyte concentration based on mass transfer of the analyte from blood to the subcutaneous region and on uptake of the analyte by subcutaneous cells surrounding the sensing
- 10 region.
2. The method of claim 1, wherein the sensing device comprises an electrochemical sensor having a working electrode.
- 15 3. The method of claim 2, further comprising subcutaneously implanting the working electrode to generate a signal related to the subcutaneous analyte concentration.
4. The method of claim 1, wherein the analyte is glucose.
- 20 5. The method of claim 4, wherein the blood glucose concentration is determined from the subcutaneous glucose concentration using the relationship:

$$V \frac{dS}{dt} = k_m A (B - S) - \frac{V k_r S}{K_m + S} \quad (1)$$

where V is the volume of the sensor, S is the subcutaneous glucose concentration, B is the blood glucose concentration, A is the surface area of the region surrounding

25 the sensor, k_m is a mass transfer coefficient, K_m is a Michaelis-Menten constant, and k_r is the reaction rate constant for uptake of glucose by the subcutaneous tissue.

6. The method of claim 5, wherein the subcutaneous glucose concentration is determined from the blood glucose concentration according to the relationship:

$$S(t) = S(\theta)e^{-\beta(t-\theta)} + \int_{\theta}^t B(\tau)e^{-\beta(t-\tau)} d\tau.$$

5 where $\beta = \left[1 + \frac{k_r}{\frac{K_m}{B_0} + S} \right]$, B_0 is a normalizing constant, θ is the initial time and t is the final time for a window of computation.

7. The method of claim 6, wherein the subcutaneous glucose concentration is determined from the blood glucose concentration using:

10
$$\int_{\theta}^t B(\tau)e^{-\beta(t-\tau)} d\tau = \sum_{i=1}^N B(t_i)e^{-\beta(t-t_i)} \Delta t \times W_i,$$

where W_i is a weighting factor.

8. The method of claim 6, wherein the subcutaneous glucose concentration is determined from the blood glucose concentration by minimizing:

15
$$f[b] = \chi^2[b] + \lambda\Psi[b],$$

where

$$\chi^2[b] = \sum_{\mu=1}^{t+N} \left(\int_{\theta}^{t_{\mu}} B(\tau)e^{-\beta(t_{\mu}-\tau)} d\tau - S(t_{\mu}) + S(\theta)e^{-\beta(t_{\mu}-\theta)} \right)^2.$$

and $\Psi[b]$ is a smoothness function.

20 9. The method of claim 8, wherein $\Psi[b]$ is selected to provide first-order regularization.

10. The method of claim 8, wherein $\Psi[b]$ is selected to provide second-order regularization.

11. An analyte measurement system, comprising:
 a sensing device; and
 a processor coupled to the sensing device and configured and arranged to
 determine an analyte level in blood, from signals generated by the sensing device,
 5 based on mass transfer of the analyte from blood to a subcutaneous region and on
 uptake of the analyte by subcutaneous cells surrounding the subcutaneous region.

12. The analyte measurement system of claim 11, wherein the sensing
 device comprises an electrochemical sensor having a working electrode.

10 13. The analyte measurement system of claim 12, wherein the working
 electrode is adapted for subcutaneous implantation in an animal.

14. The analyte measurement system of claim 11, wherein the analyte is
 15 glucose.

15. The analyte measurement system of claim 14, wherein the processor
 is configured and arranged to determine the blood glucose concentration from a
 subcutaneous glucose concentration using the relationship:

$$V \frac{dS}{dt} = k_m A (B - S) - \frac{V k_r S}{K_m + S}$$

20 where V is the volume of the sensor, S is the subcutaneous glucose concentration, B
 is the blood glucose concentration, A is the surface area of the region surrounding
 the sensor, k_m is a mass transfer coefficient, K_m is a Michaelis-Menten constant, and
 k_r is the reaction rate constant for uptake of glucose by the subcutaneous tissue.

25 16. The analyte measurement system of claim 15, wherein the processor
 is configured and arranged to determine the blood glucose concentration from a
 subcutaneous glucose concentration using the relationship:

$$S(t) = S(\theta) e^{-\beta(t-\theta)} + \int_{\theta}^t B(\tau) e^{-\beta(t-\tau)} d\tau.$$

where $\beta = \left[1 + \frac{k_r}{\frac{K_m}{B_0} + S} \right]$, B_0 is a normalizing constant, θ is the initial time and t is the

final time for a window of computation.

17. The analyte measurement system of claim 16, wherein the processor
5 is configured and arranged to determine the blood glucose concentration from a subcutaneous glucose concentration using the relationship:

$$\int_{\theta}^t B(\tau) e^{-\beta(t-\tau)} d\tau = \sum_{i=1}^N B(t_i) e^{-\beta(t-t_i)} \Delta t \times W_i$$

where W_i is a weighting factor.

- 10 18. The analyte measurement system of claim 16, wherein the processor is configured and arranged to determine the blood glucose concentration from a subcutaneous glucose concentration by minimizing:

$$f[b] = \chi^2[b] + \lambda \Psi[b],$$

where

15
$$\chi^2[b] = \sum_{\mu=1}^{l+N} \left(\int_{\theta}^{t_{\mu}} B(\tau) e^{-\beta(t_{\mu}-\tau)} d\tau - S(t_{\mu}) + S(\theta) e^{-\beta(t_{\mu}-\theta)} \right)^2$$

and $\Psi[b]$ is a smoothness function.

19. The analyte measurement system of claim 18, wherein $\Psi[b]$ is selected to provide first-order regularization.
- 20 20. The analyte measurement system of claim 18, wherein $\Psi[b]$ is selected to provide second-order regularization.

21. The analyte measurement system of claim 11, further comprising a
25 display coupled to the processor for displaying the analyte concentration in the blood.

22. The analyte measurement system of claim 11, further comprising an alarm coupled to the processor for alerting a user based on the analyte concentration.

23. The analyte measurement system of claim 11, wherein the processor is disposed in a housing adapted for placement on the skin of an animal.

24. The analyte measurement system of claim 23, further comprising a transmitter coupled to the electrochemical sensor and a receiver coupled to the processor, wherein the processor and receiver are disposed in a housing adapted for remote reception of signals from the electrochemical sensor via the transmitter.

25. An apparatus for determining analyte concentration in blood based on measurements of analyte concentration determined using a sensing device, comprising:

a processor configured and arranged to determine analyte concentration in the blood from a measured subcutaneous analyte concentration based on mass transfer of the analyte from blood to a subcutaneous region and on uptake of the analyte by subcutaneous cells surrounding the subcutaneous region.

26. The apparatus of claim 25, wherein the analyte is glucose.

27. A method for determining analyte concentration in a first body fluid, comprising:

obtaining measurements of an analyte concentration in a second body fluid,

different from the first body fluid, from a sensing device; and

determining an analyte concentration estimate in the first fluid from the measurements by minimizing the relation:

$$f[b] = \chi^2[b] + \lambda\Psi[b],$$

wherein b is a vector representing analyte concentration in the first body fluid, $\chi^2[b]$

is a function representing a fit between the estimates and the measurements, λ is a

weighting function, and $\Psi[b]$ is a function indicating smoothness of the analyte

concentration estimates in the first body fluid.

28. The method of claim 27, wherein the analyte is glucose.

29. The method of claim 28, wherein the first body fluid is blood and the
5 second body fluid is subcutaneous fluid.

30. The method of claim 28, wherein the model is based on the
relationship:

$$V \frac{dS}{dt} = k_m A (B - S) - \frac{V k_r S}{K_m + S}$$

where V is the volume of the sensor, S is the subcutaneous glucose concentration, B
10 is the blood glucose concentration, A is the surface area of the region surrounding
the sensor, k_m is a mass transfer coefficient, K_m is a Michaelis-Menten constant, and
 k_r ' is the reaction rate constant for uptake of glucose by the subcutaneous tissue.

31. The method of claim 27, wherein $\Psi[b]$ is selected to provide first-
15 order regularization.

32. The method of claim 27, wherein $\Psi[b]$ is selected to provides second-
order regularization.

20 33. The method of claim 29, wherein obtaining subcutaneous glucose
measurements comprises

subcutaneously implanting a working electrode of a glucose sensor into an
animal; and

25 determining a subcutaneous glucose concentration from a signal generated at
the working electrode.

34. An analyte measurement system, comprising:
a sensing device; and

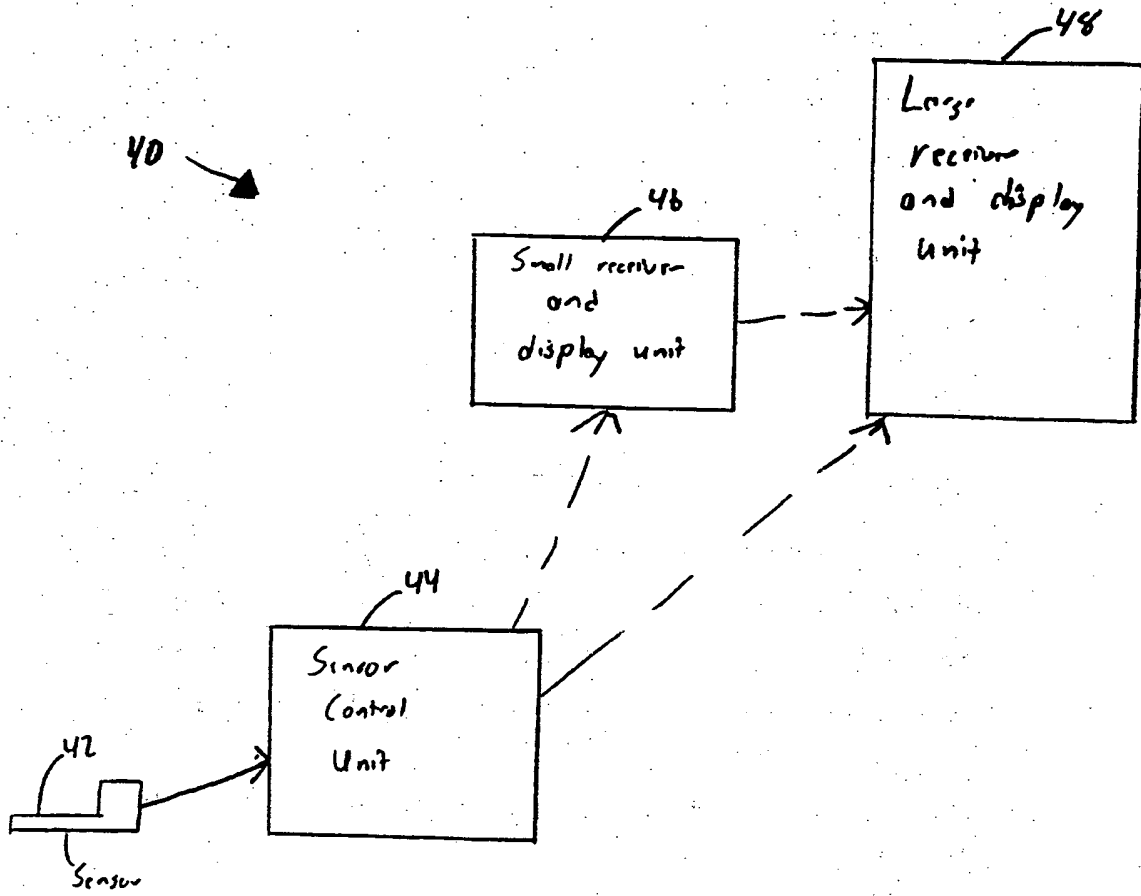

Fig. 1

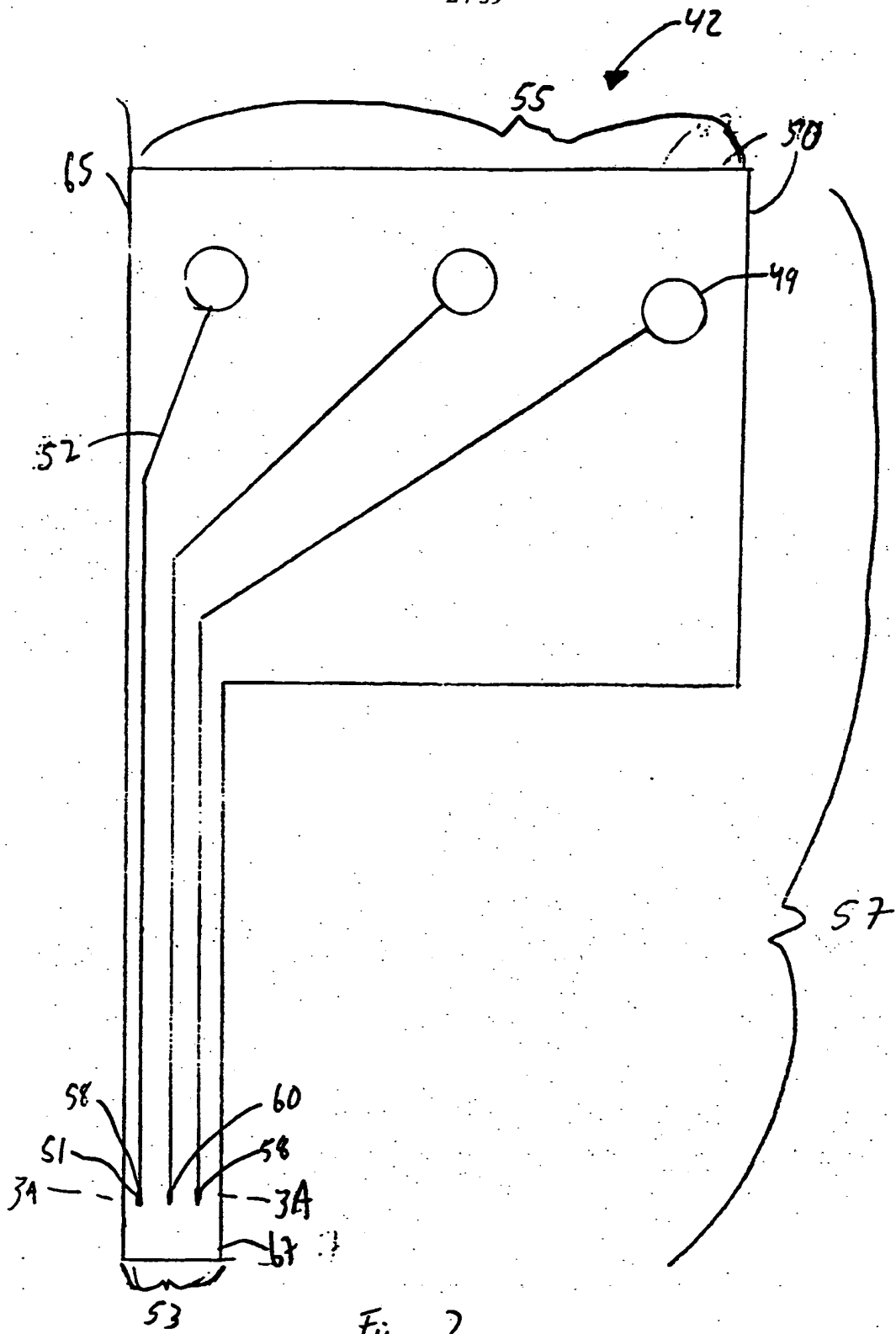

Fig. 2

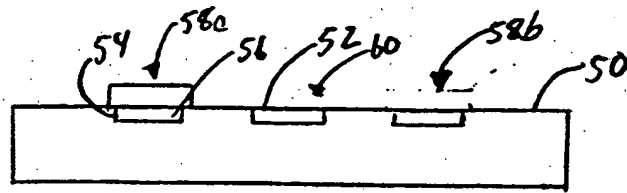

Fig. 3A

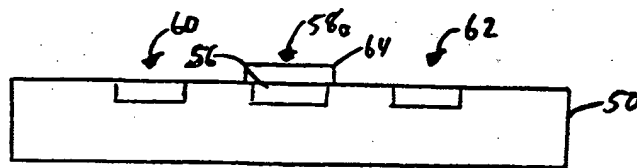

Fig. 3B

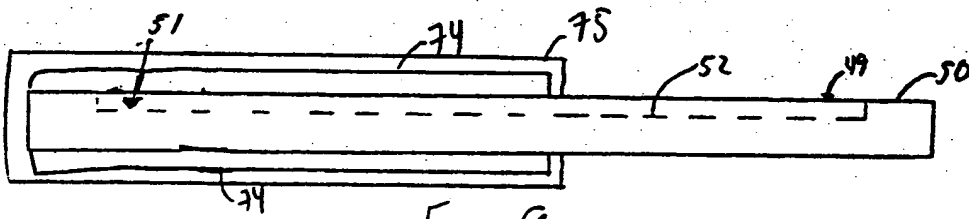

Fig. 9

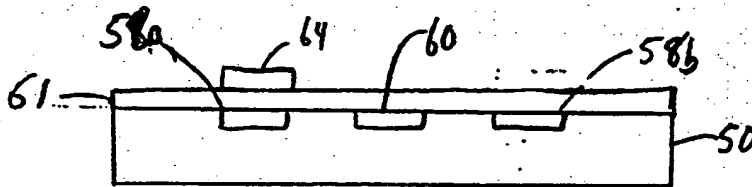

Fig. 4A

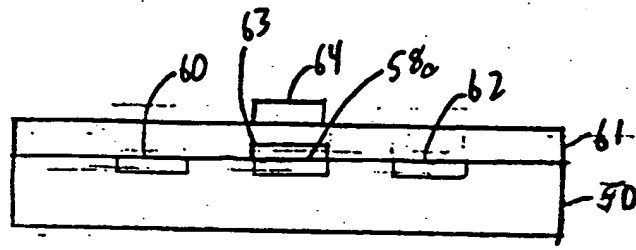

Fig. 4B

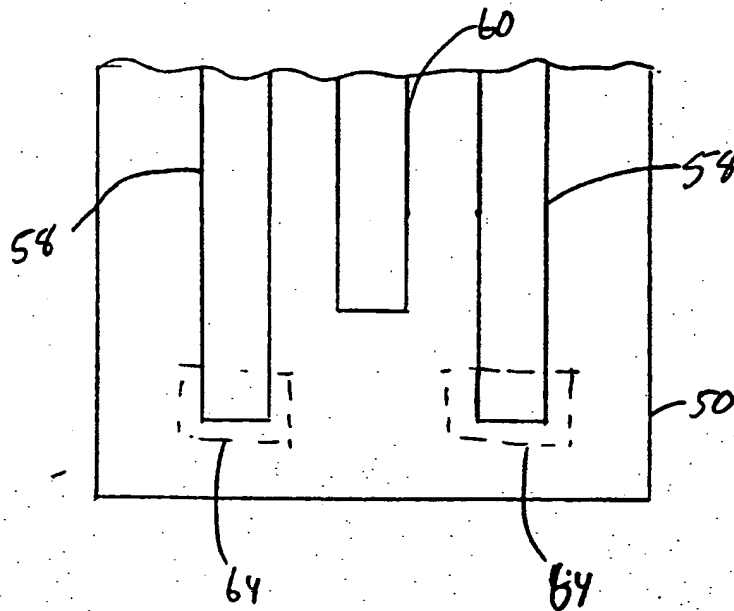

Fig. 5

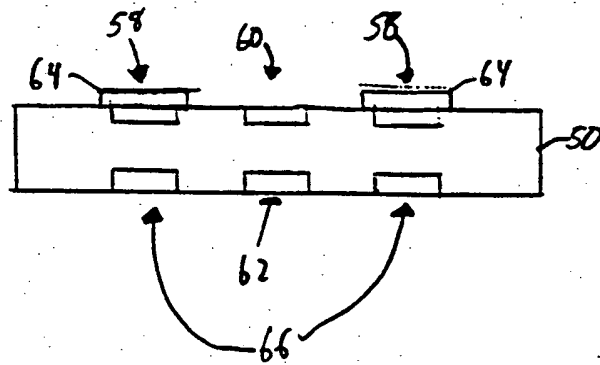

Fig. 6

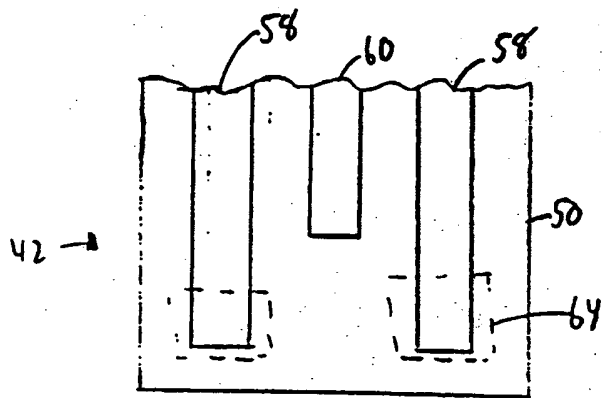

Fig. 7

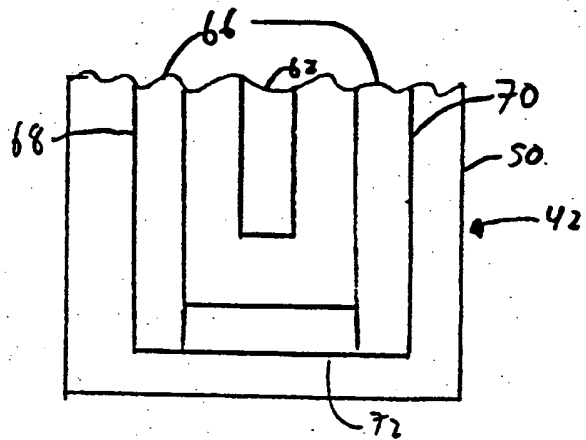

Fig. 8

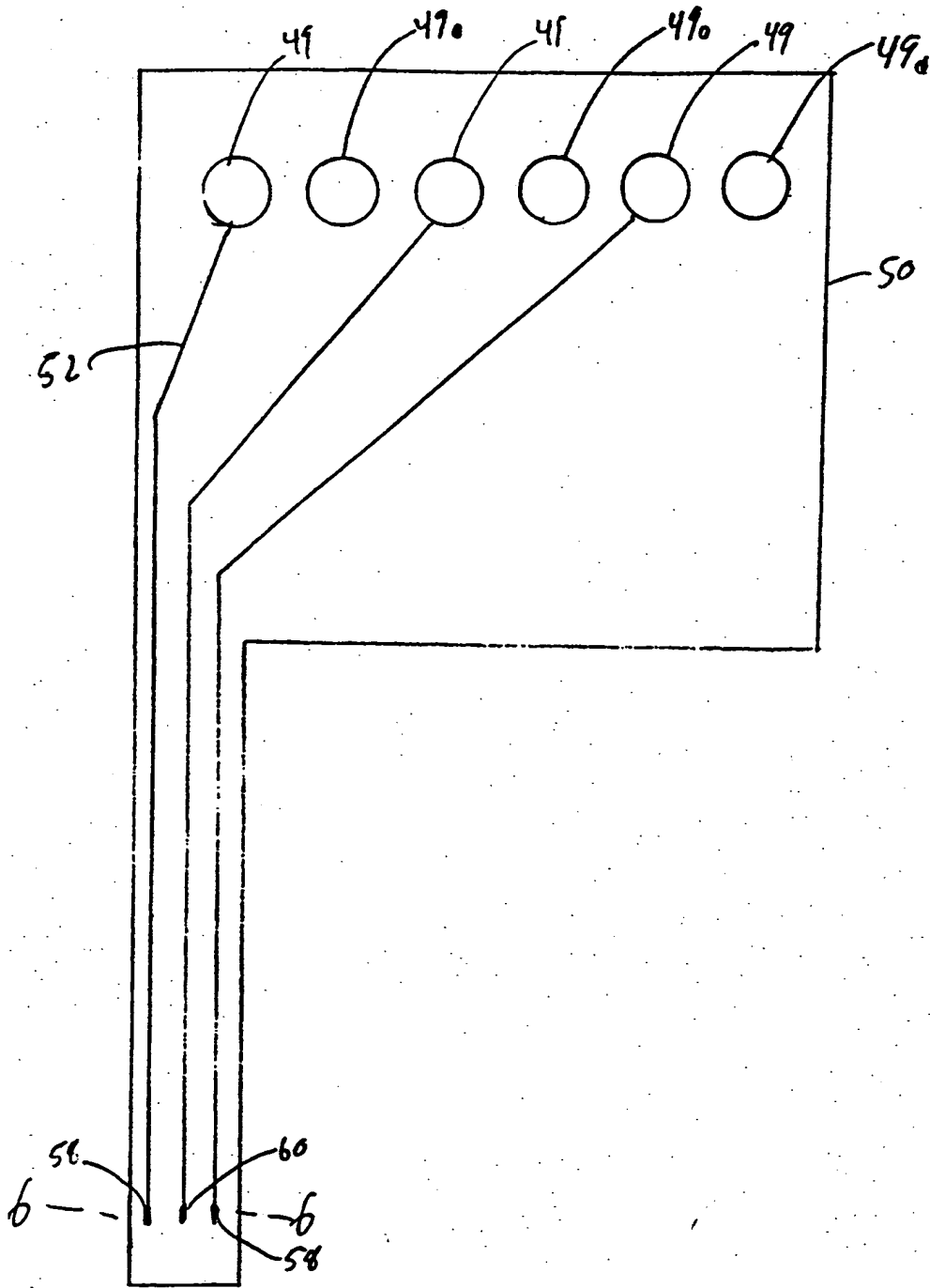

Fig. 10

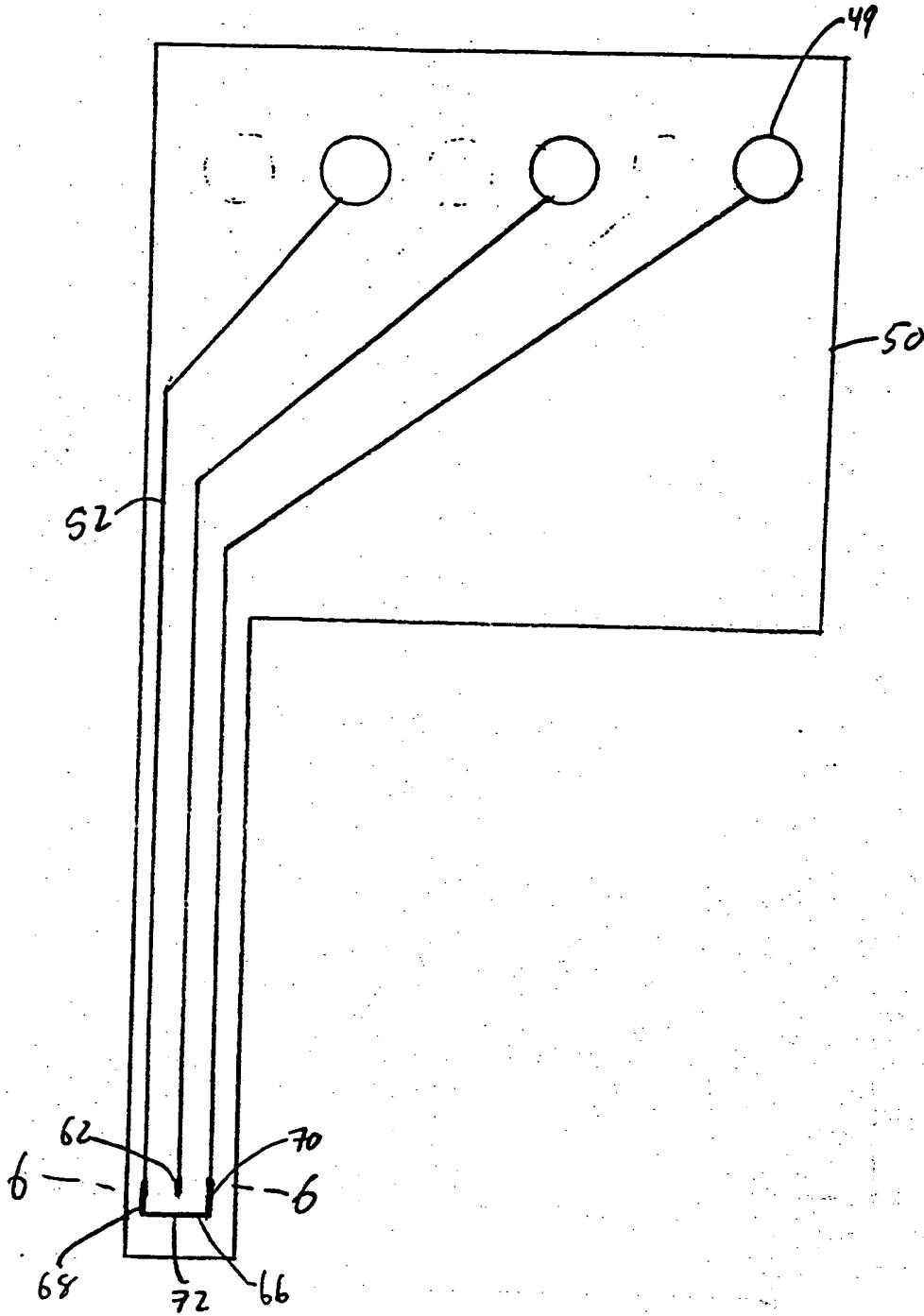

Fig. 11

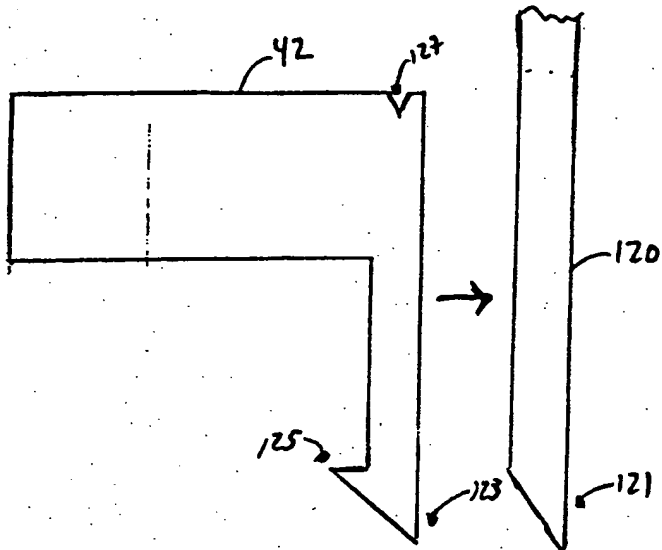

Fig. 12

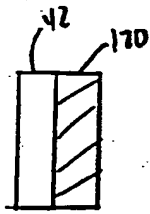

Fig. 13A

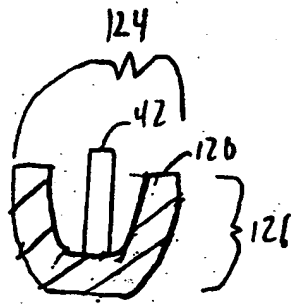

Fig. 13B

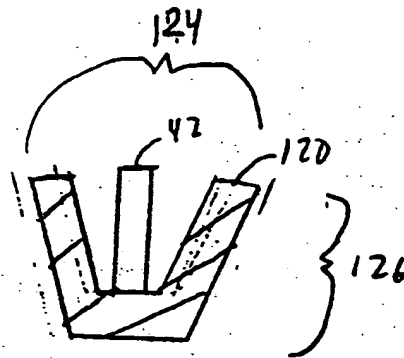

Fig. 13C

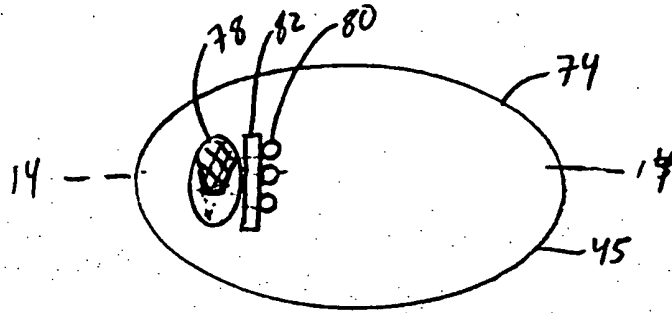

Fig. 15

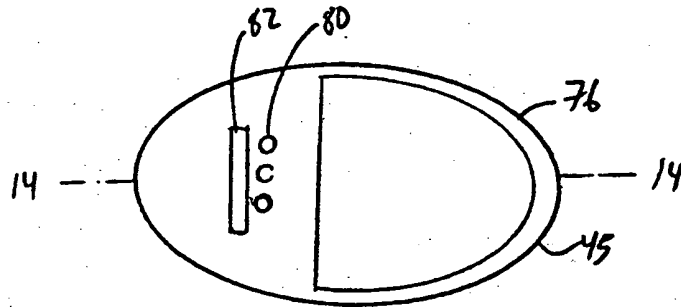

Fig. 16

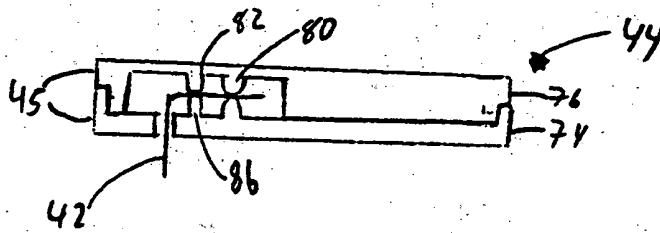

Fig. 14

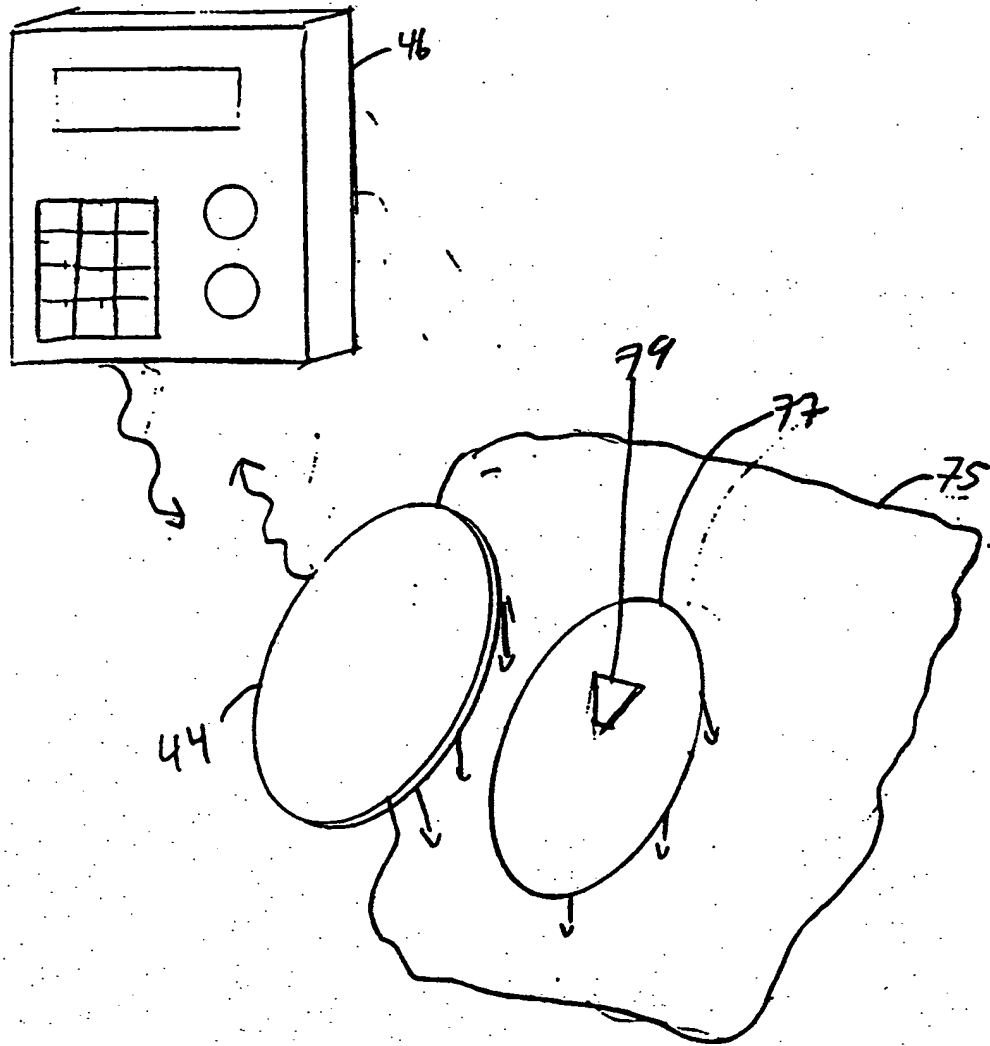

Fig. 17

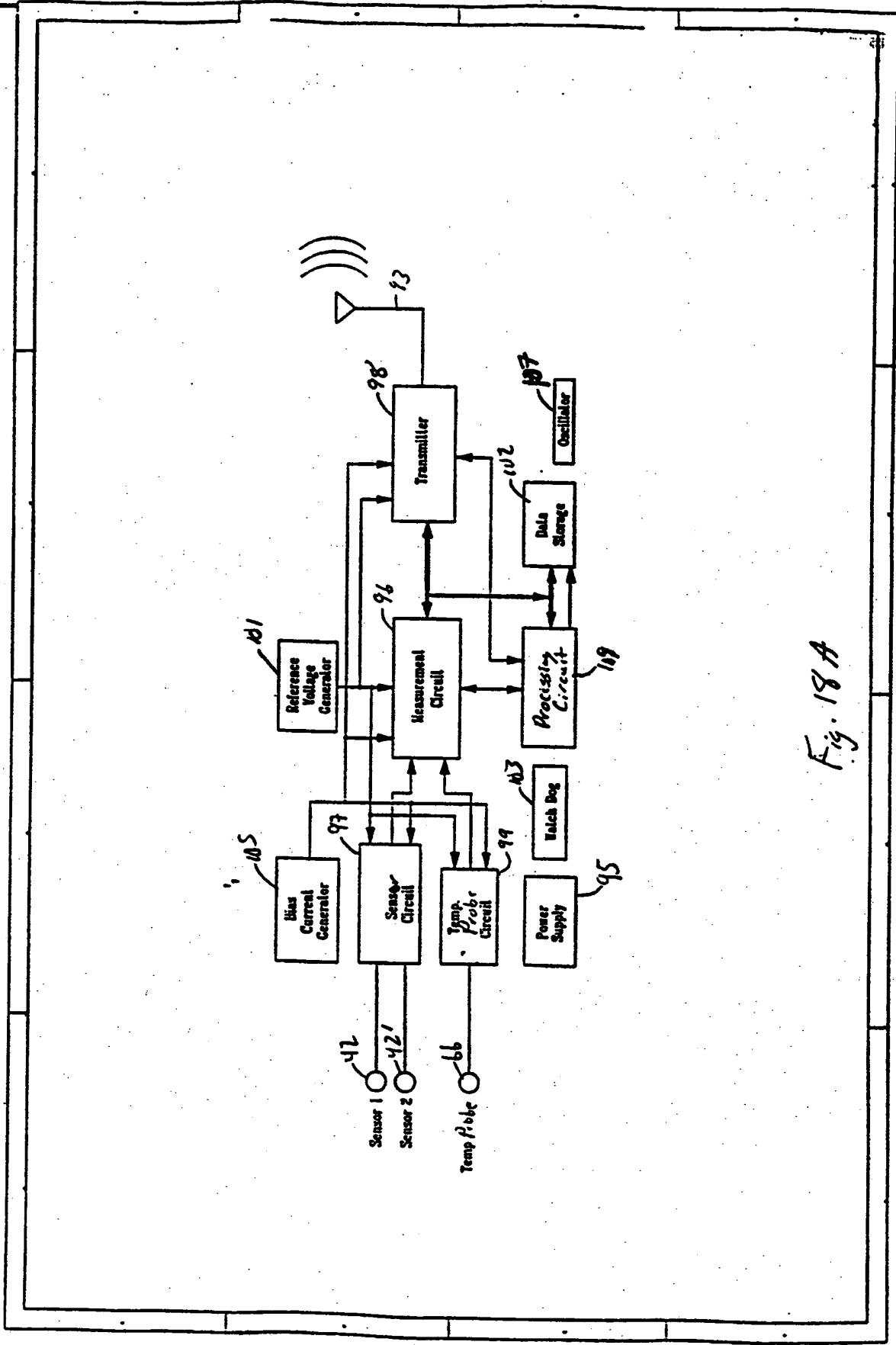

Fig. 18A

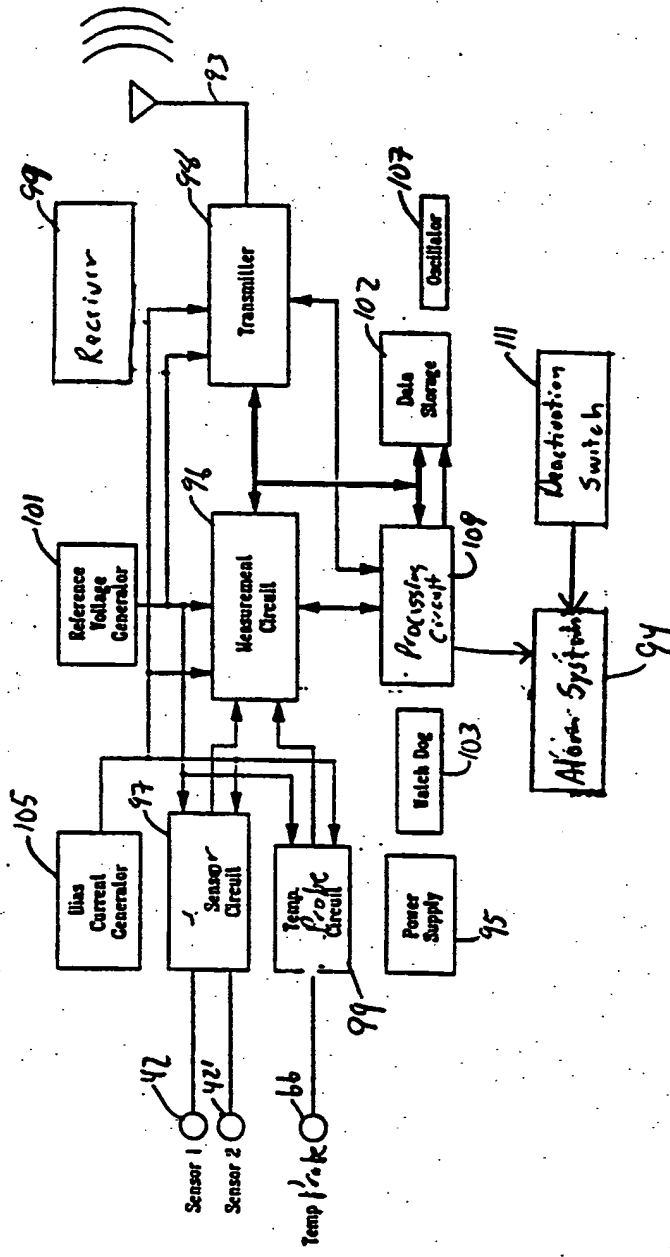

Fig. 18B

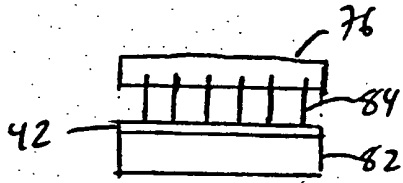

Fig. 19A

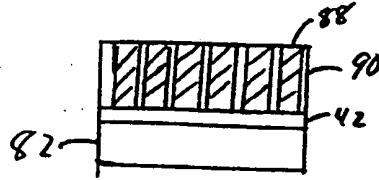

Fig. 19B

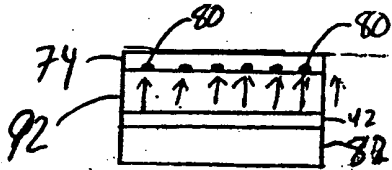

Fig. 19C

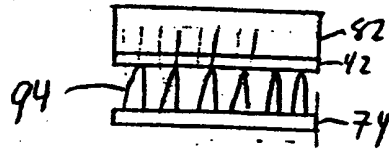

Fig. 19D

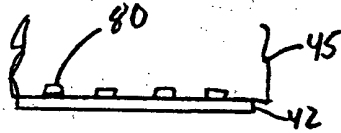

Fig. 19E

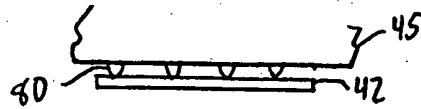

Fig. 19F

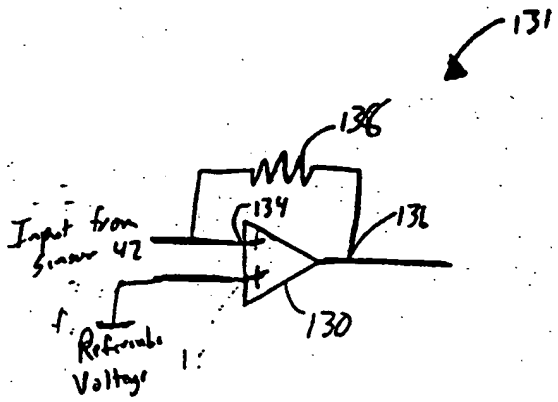

Fig. 20A

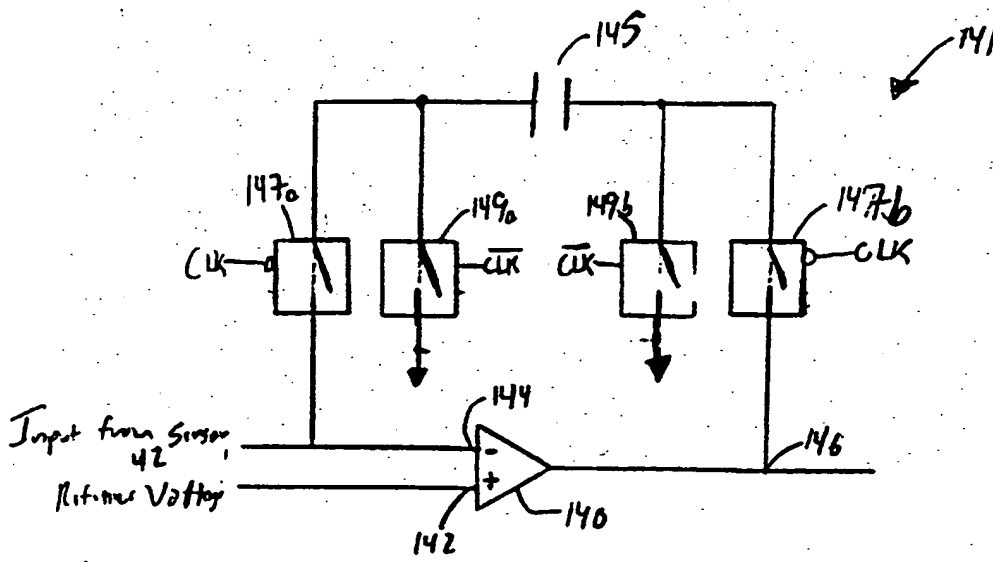

Fig. 20B

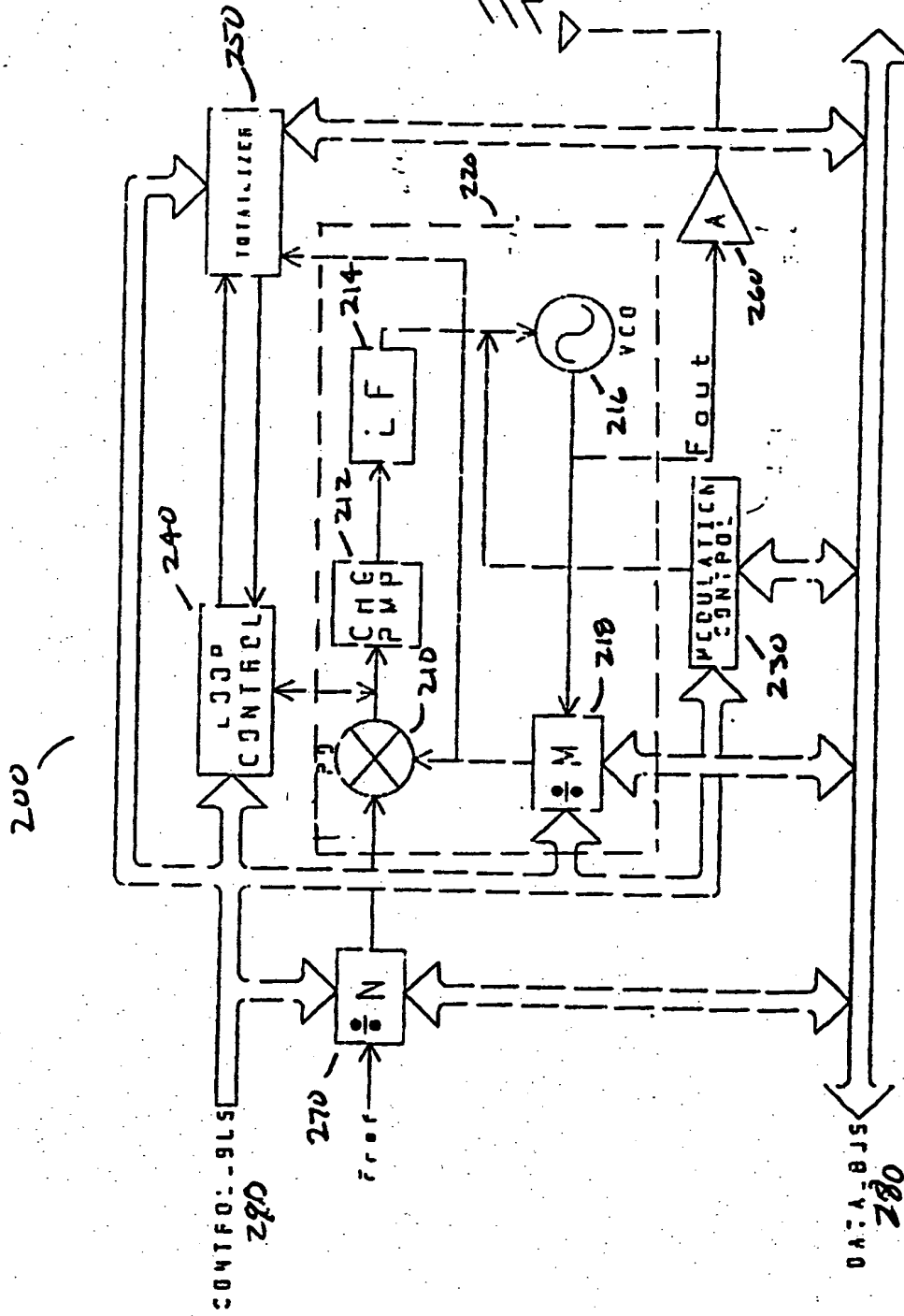

Fig. 21

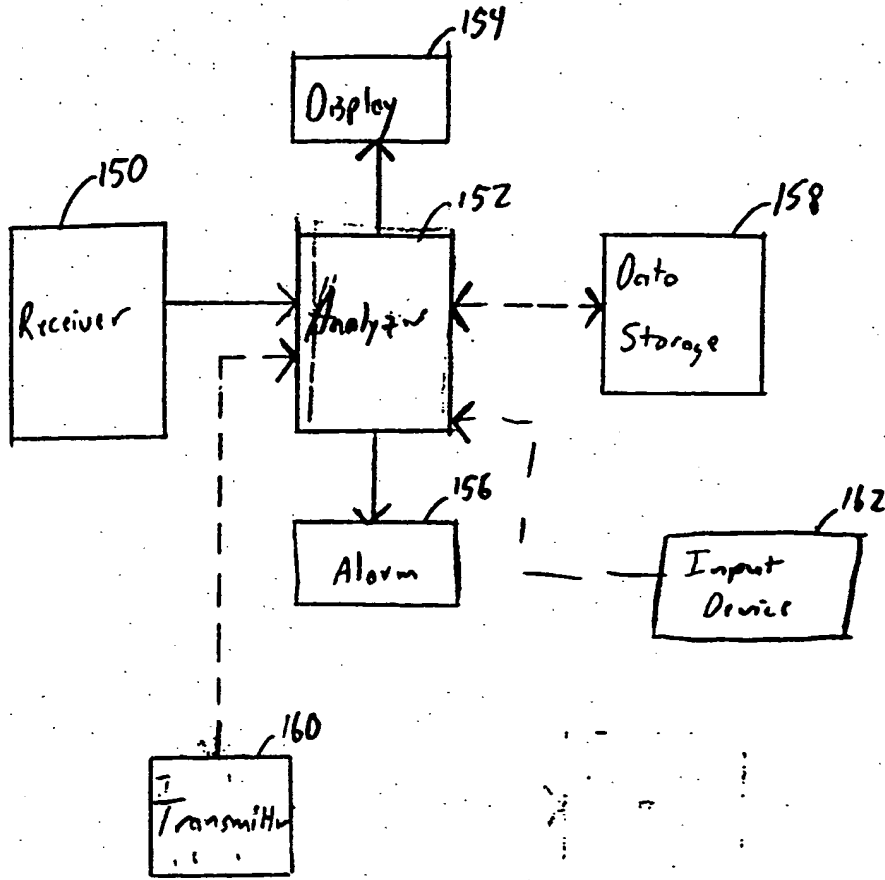

Fig. 22

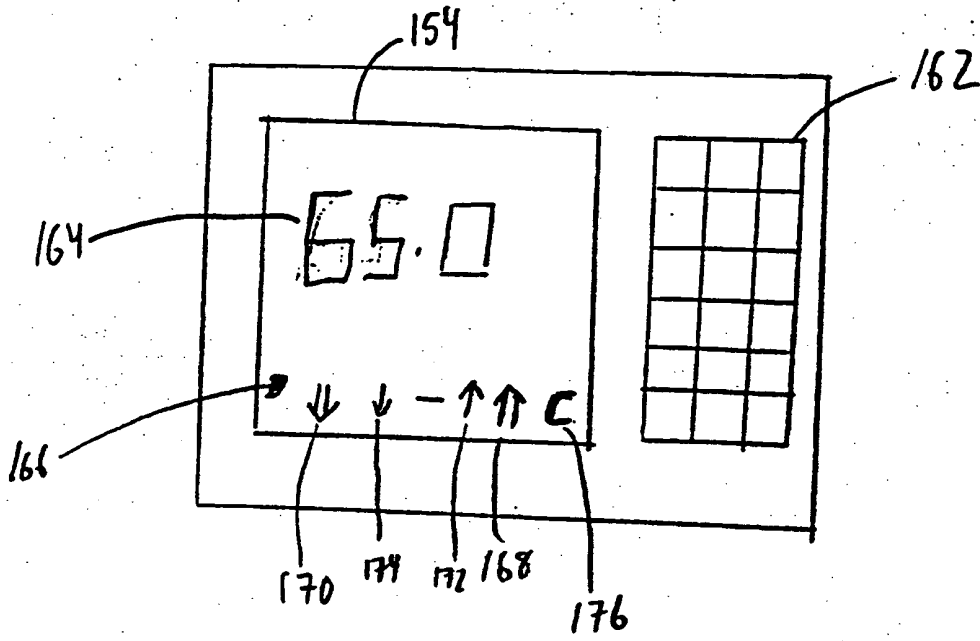

Fig. 23

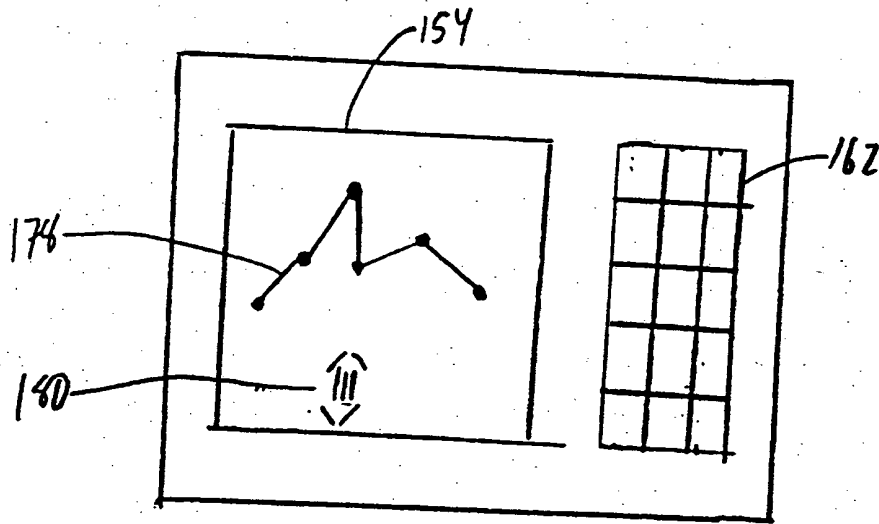

Fig. 24

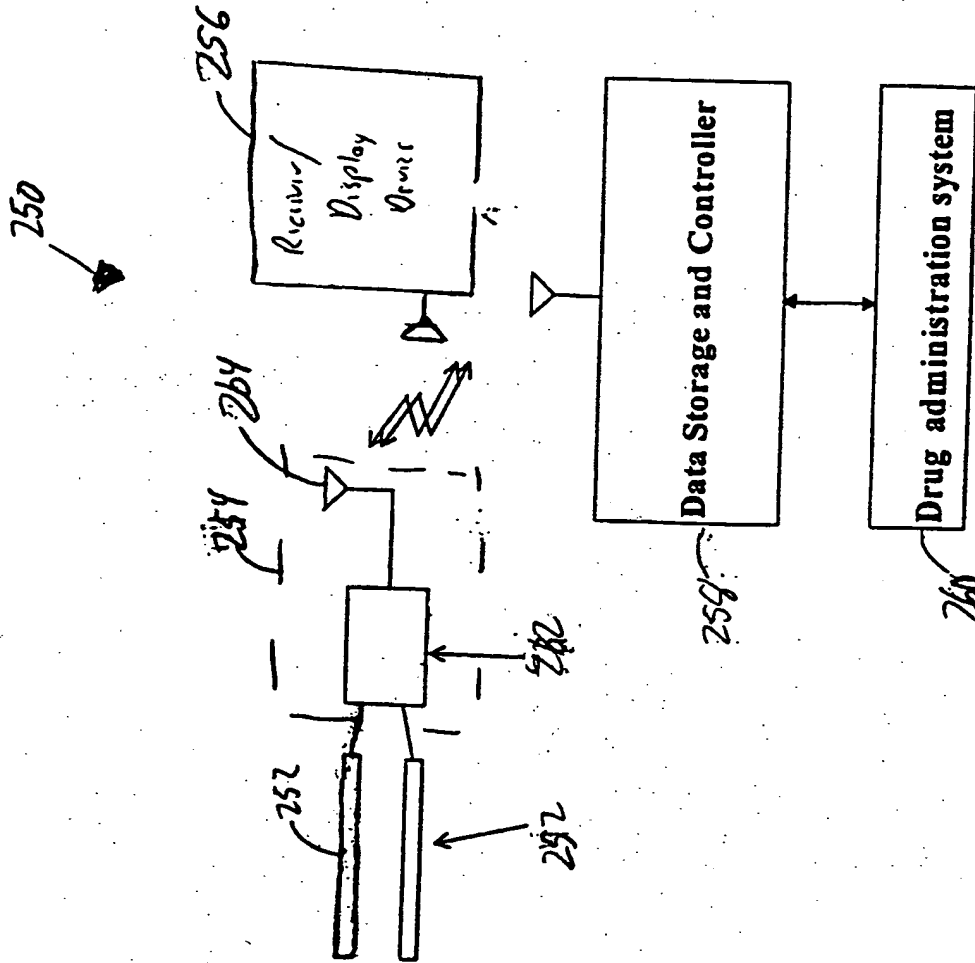

Fig. 25

Figure 26 (continued)

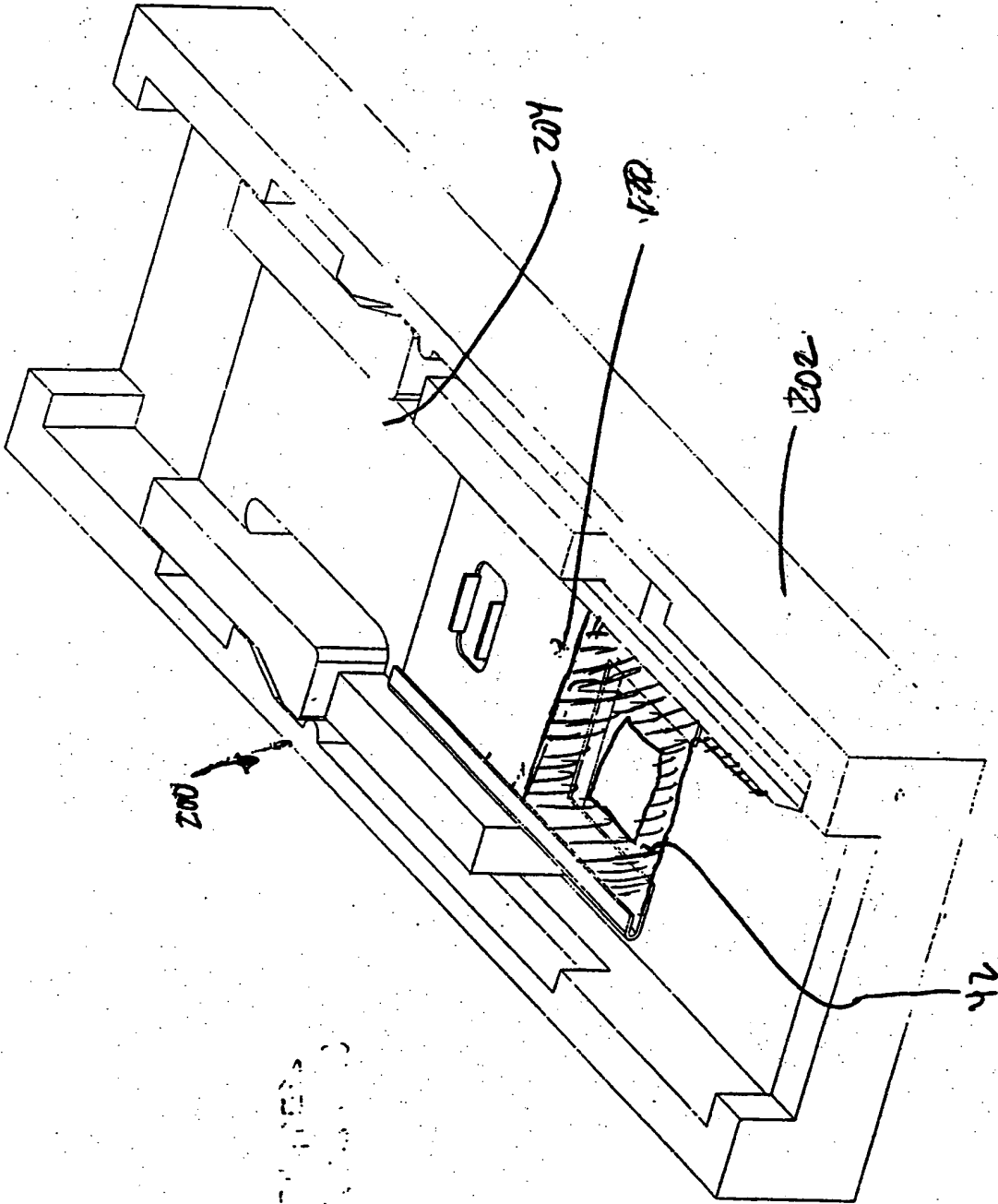

Fig. 26

FIG. 26
continued

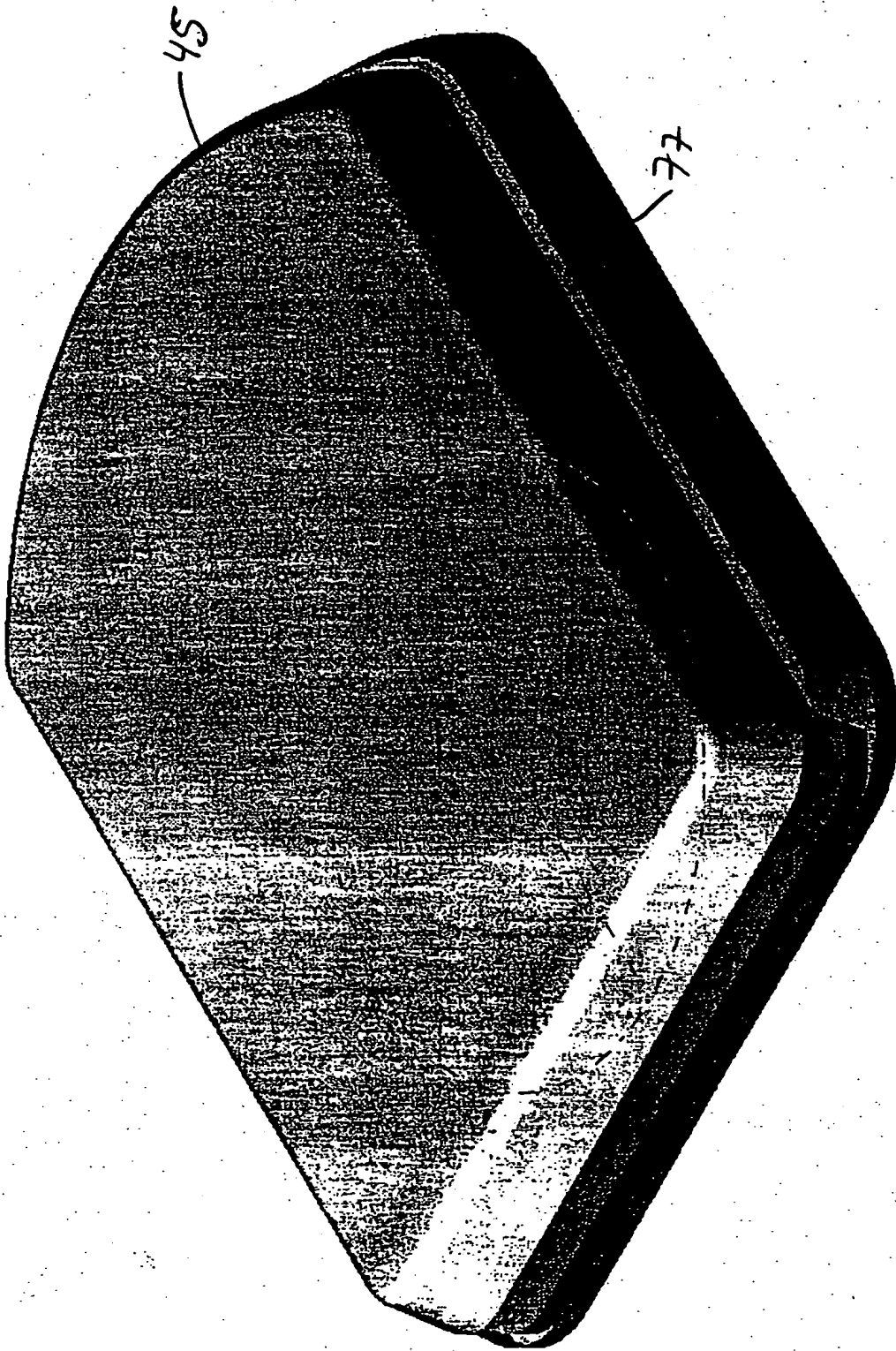

Fig. 27A

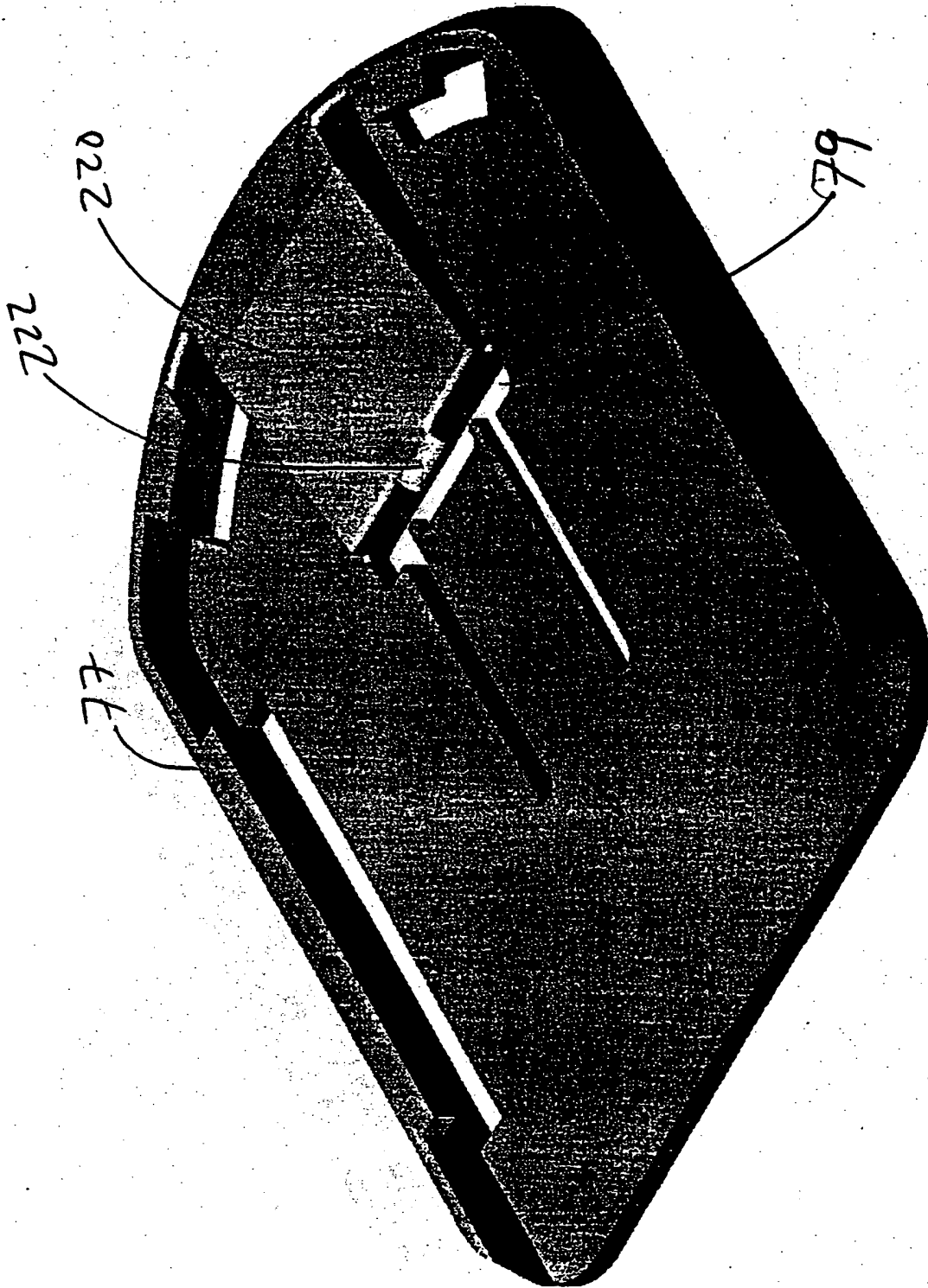

Fig. 27B

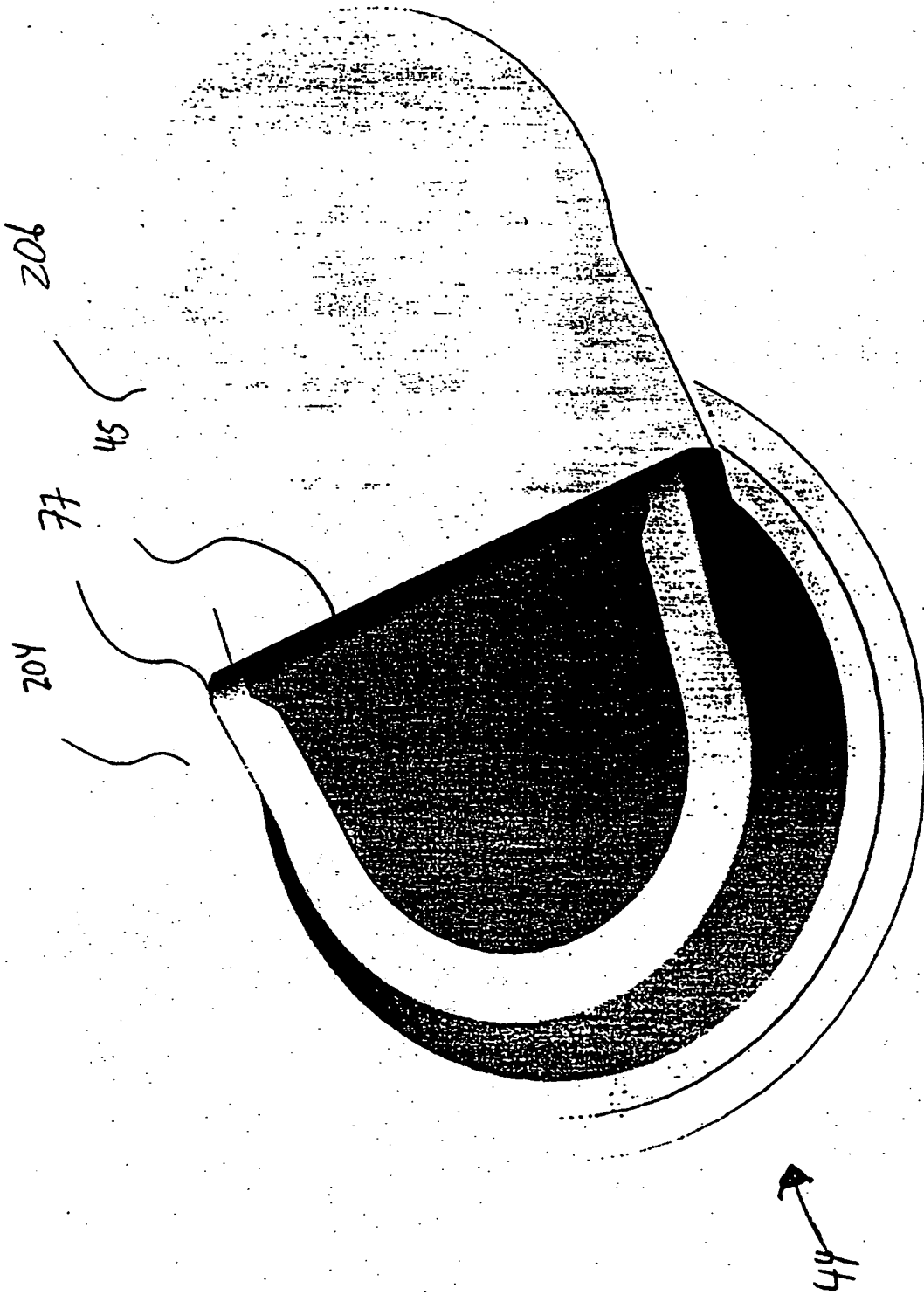

Fig. 28A

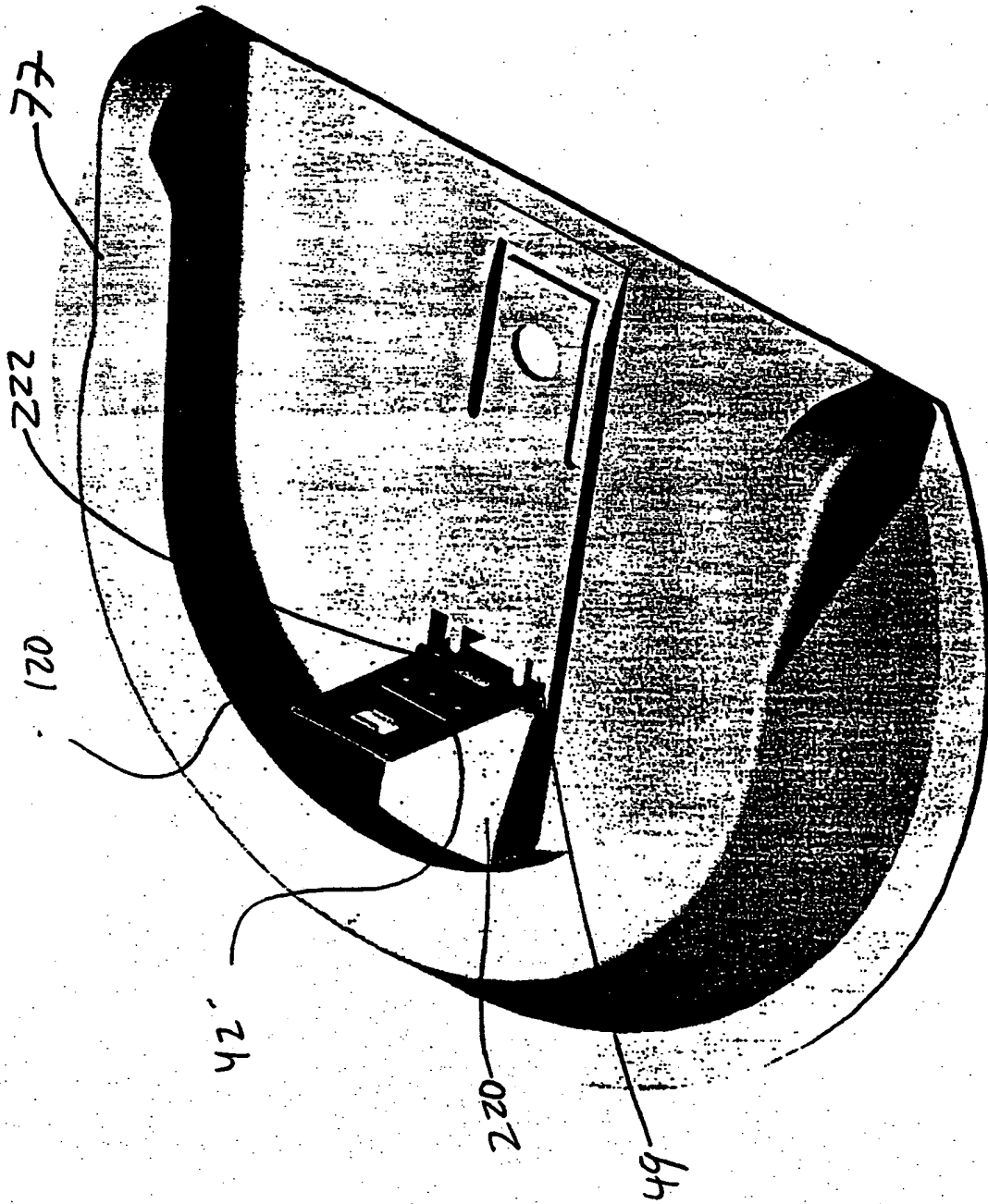

Fig. 28B

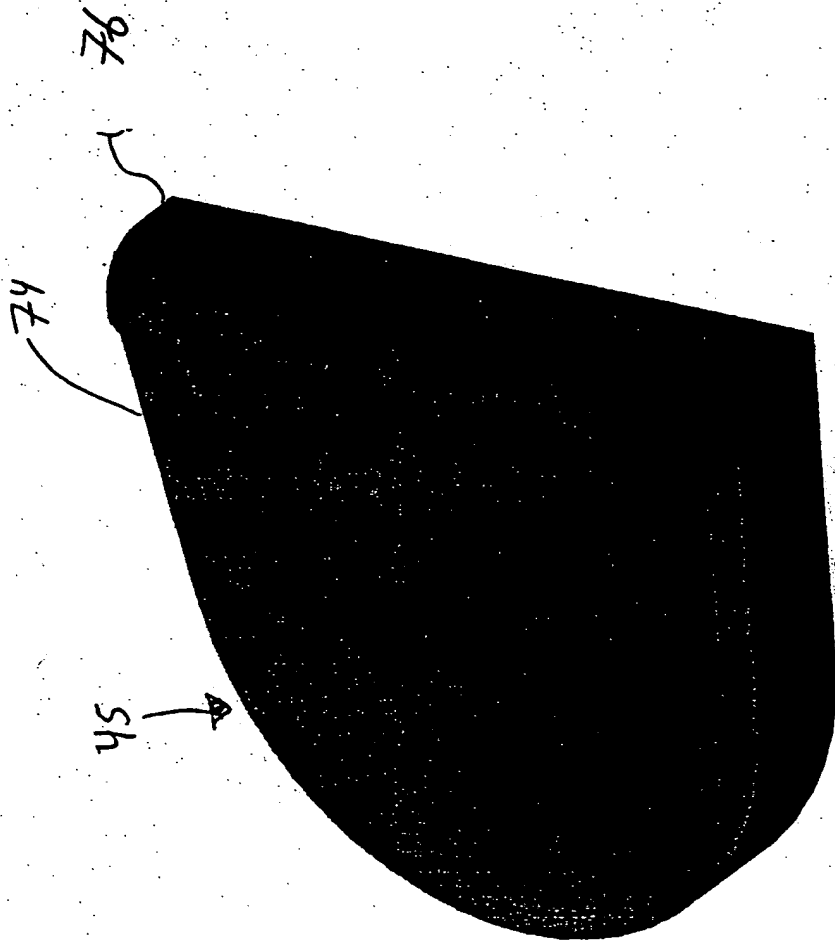

Fig. 28c

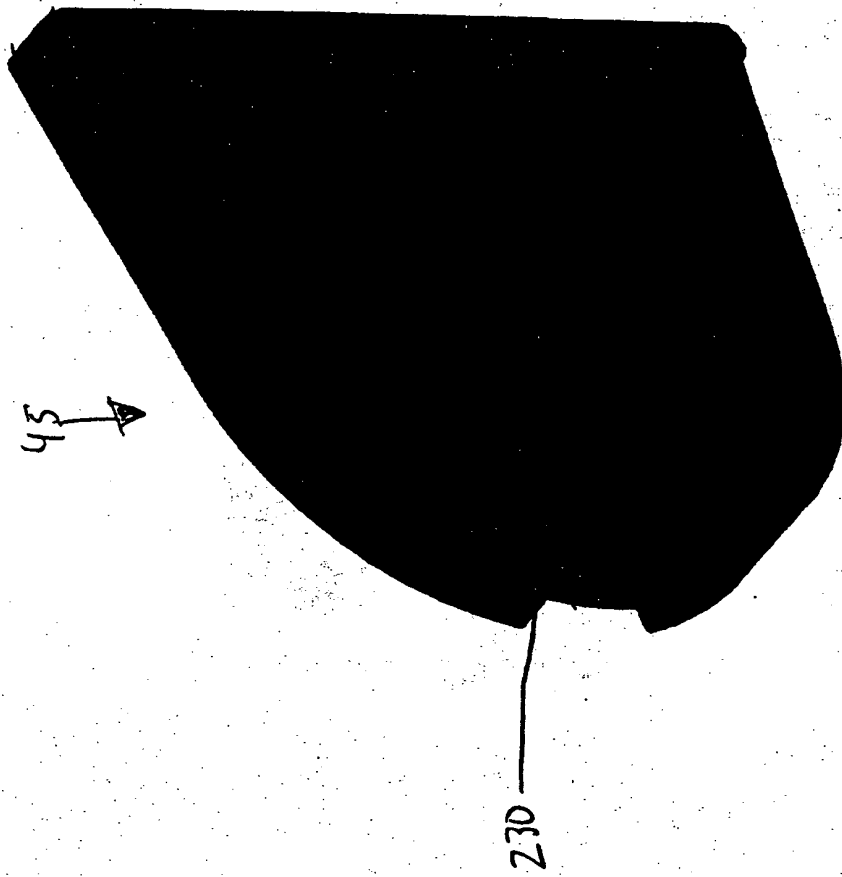

Fig. 28D

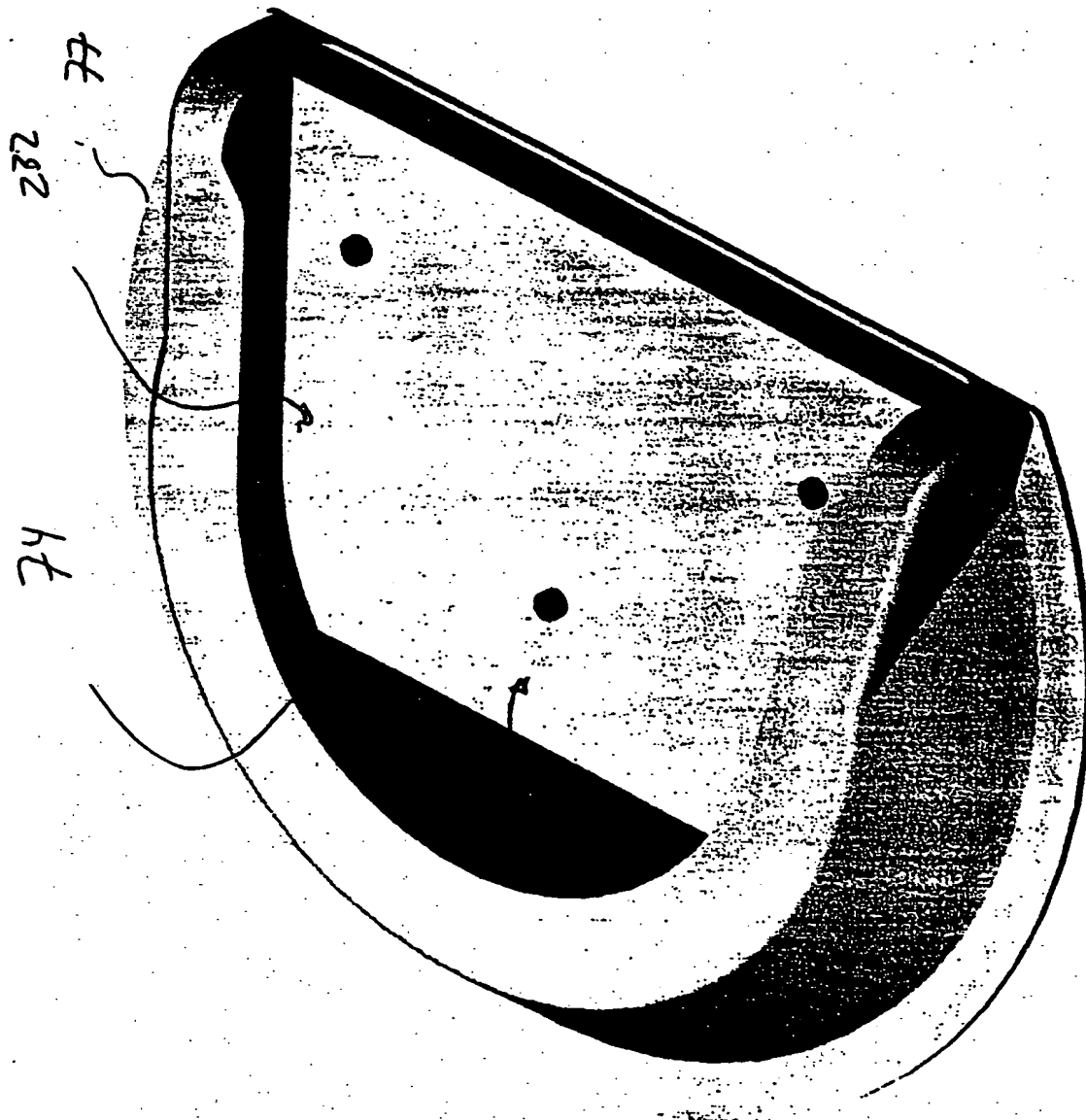

Fig. 28E

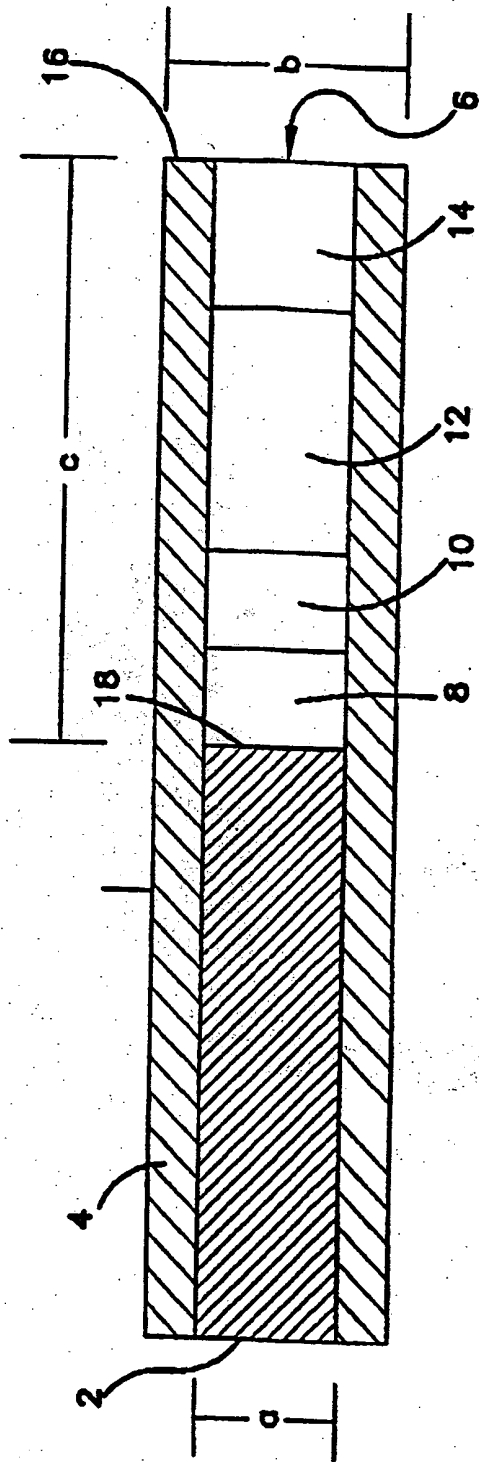

FIG. 29

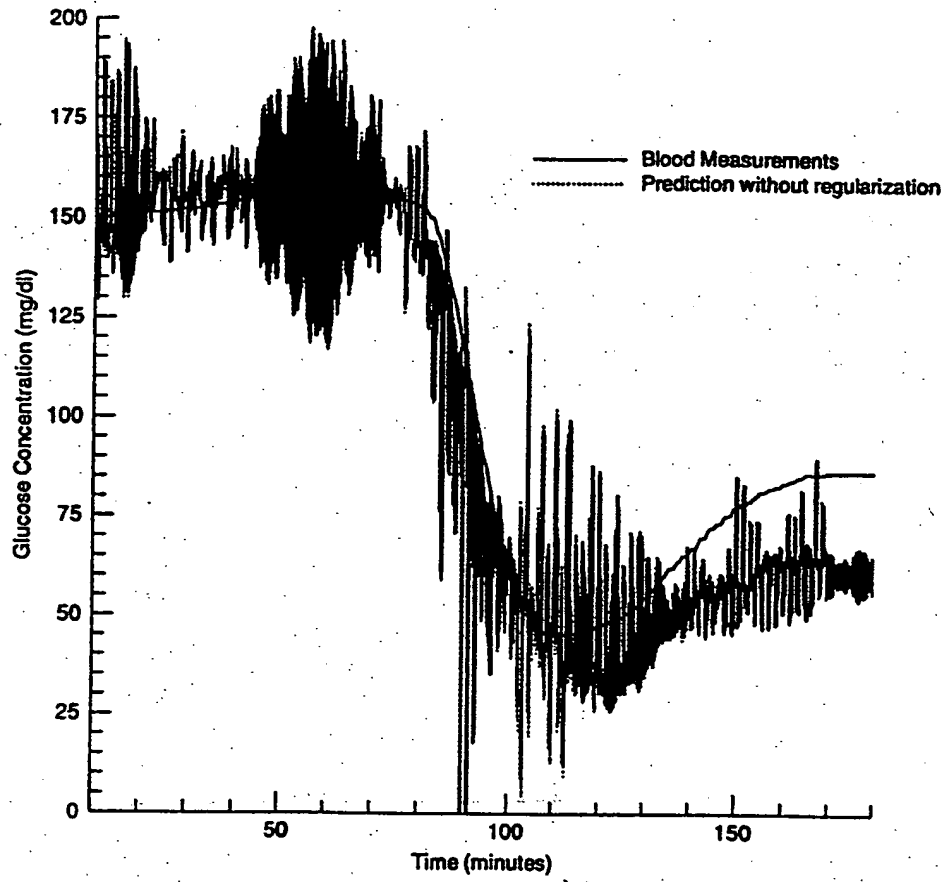

Fig. 30

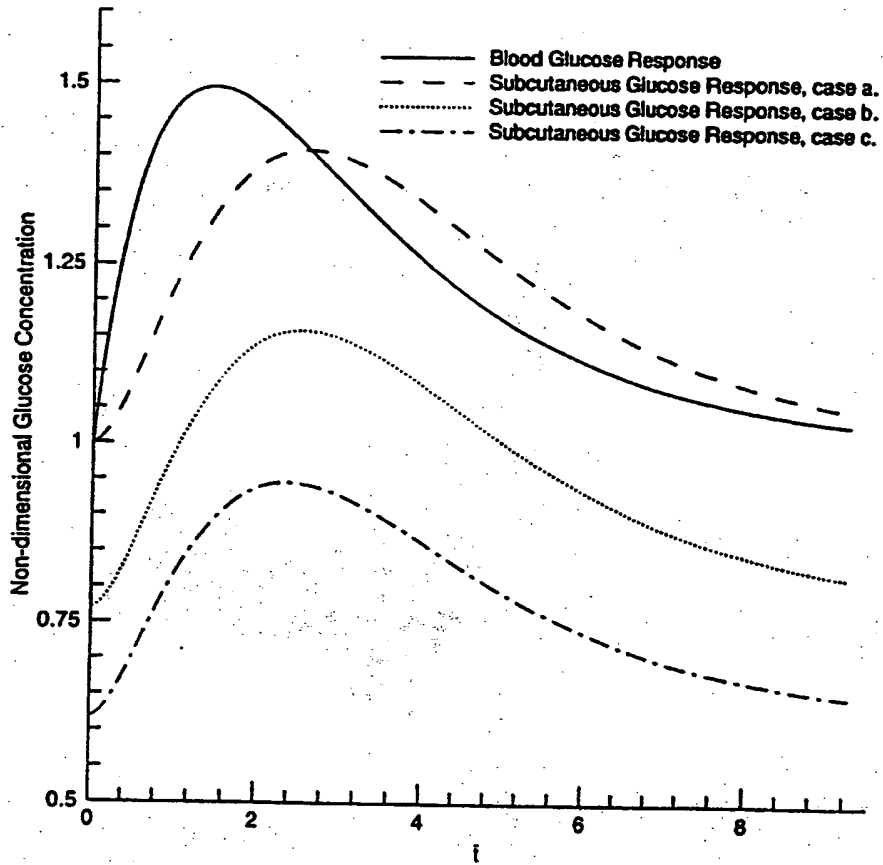

Fig. 31

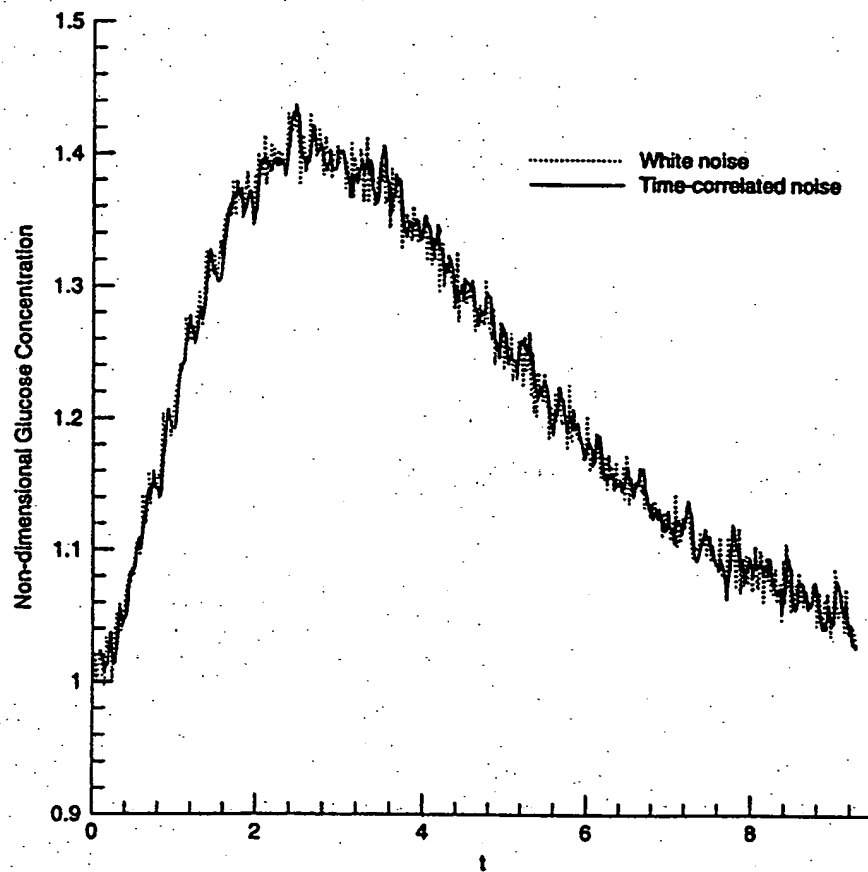

Fig. 32

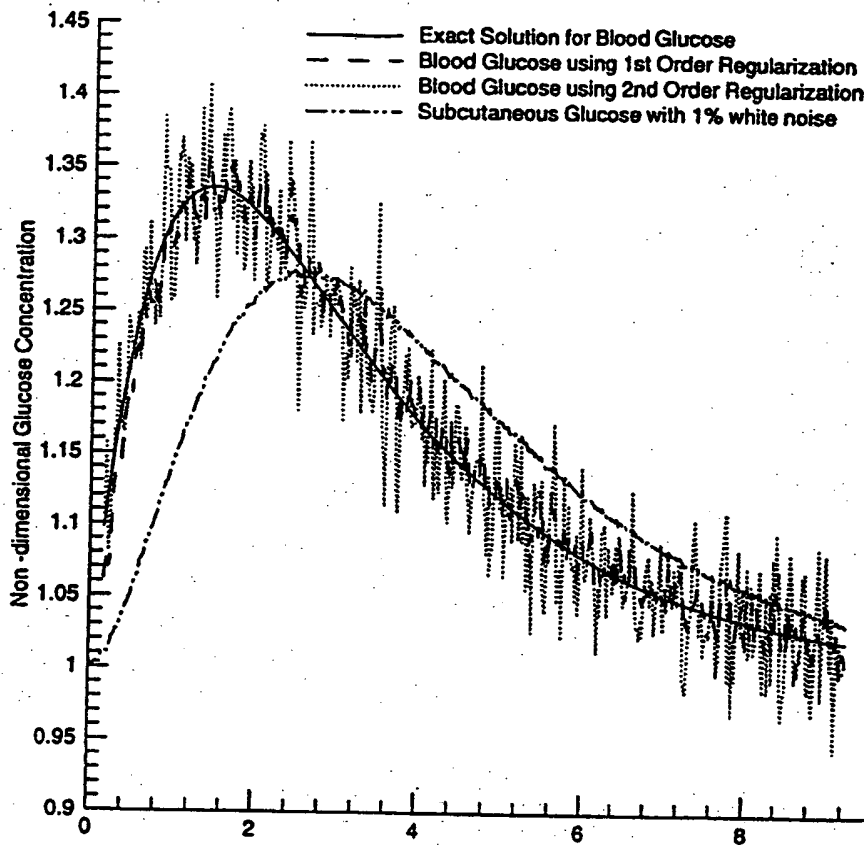

Fig. 33

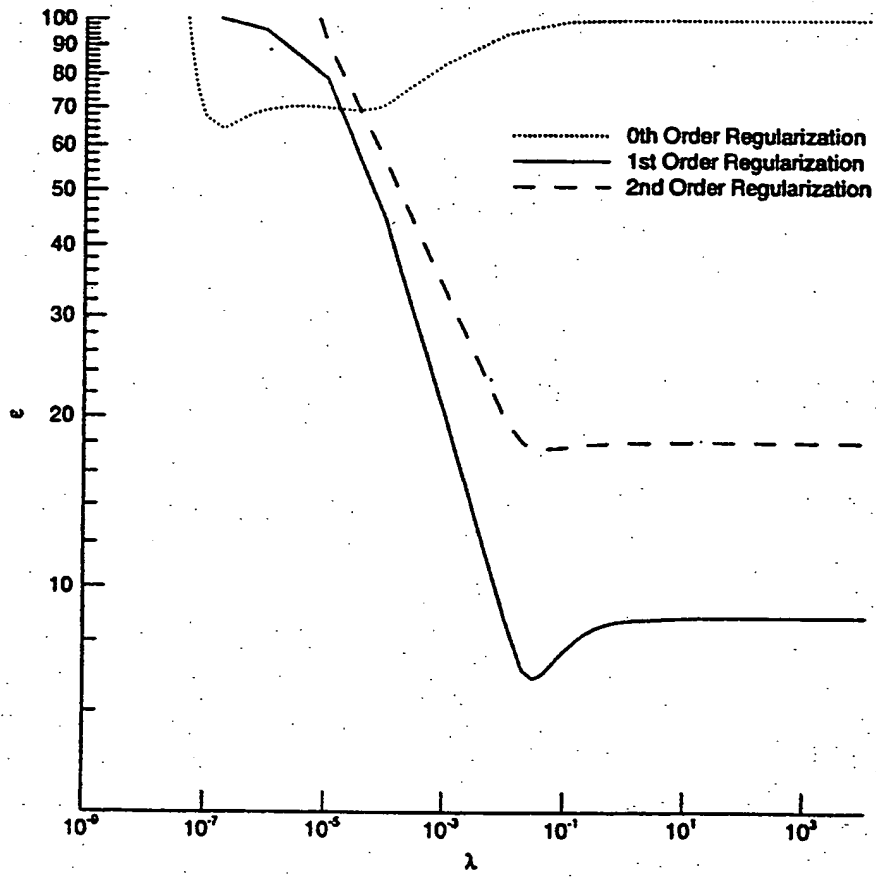

Fig. 34

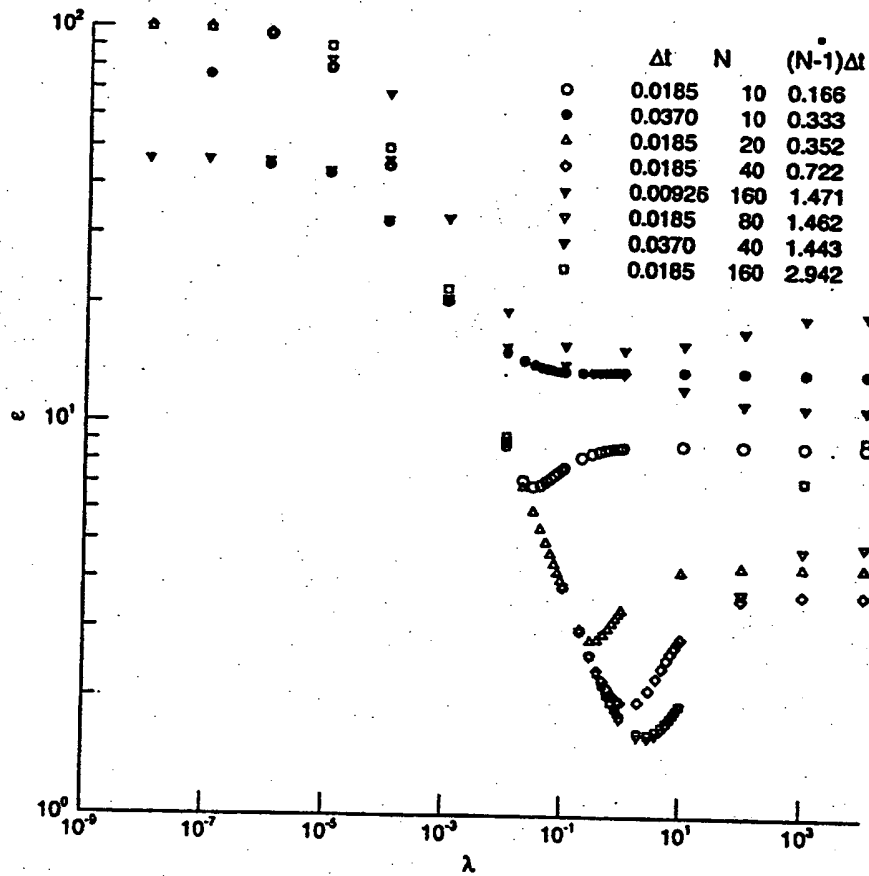

Fig 35

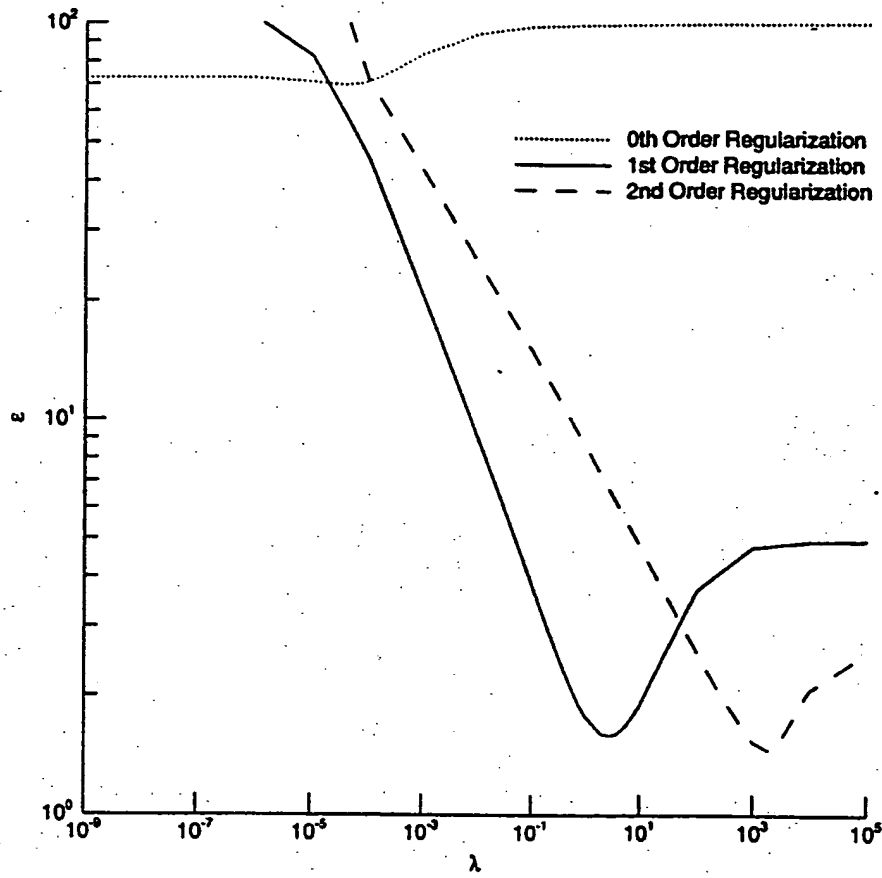

Fig. 36

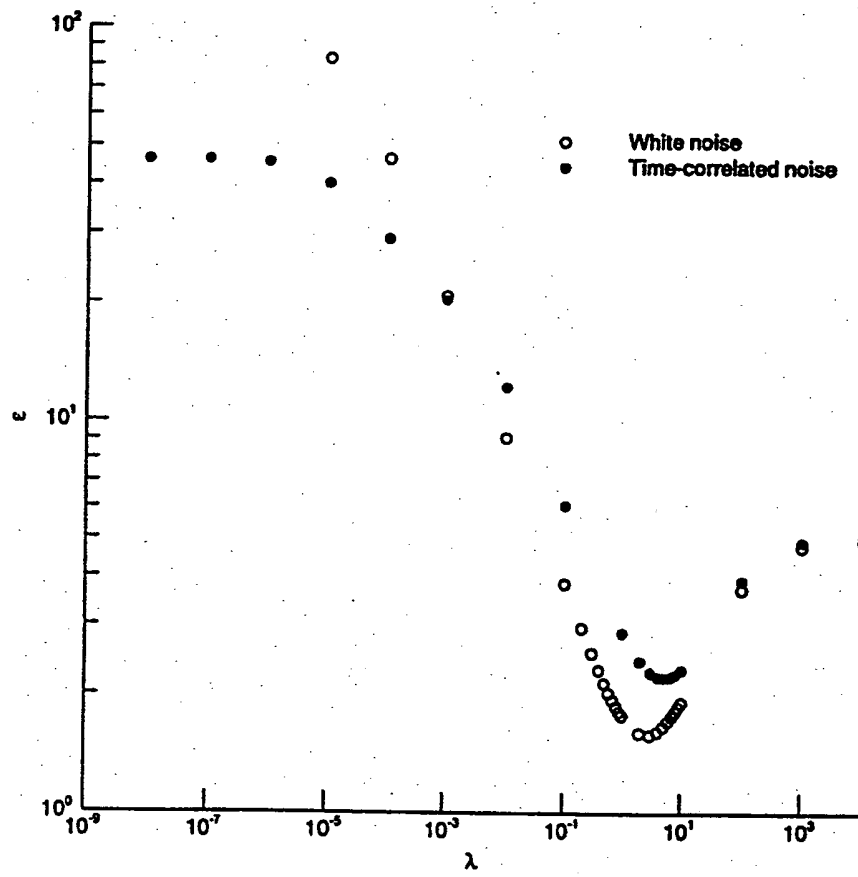

Fig. 37

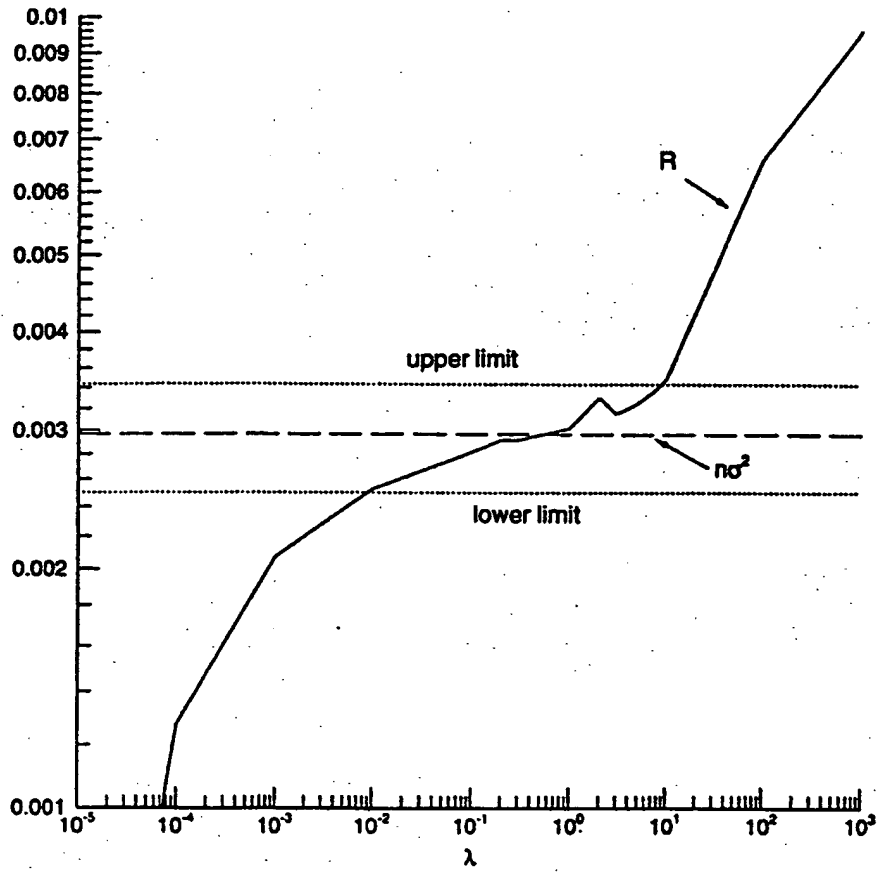

Fig. 38

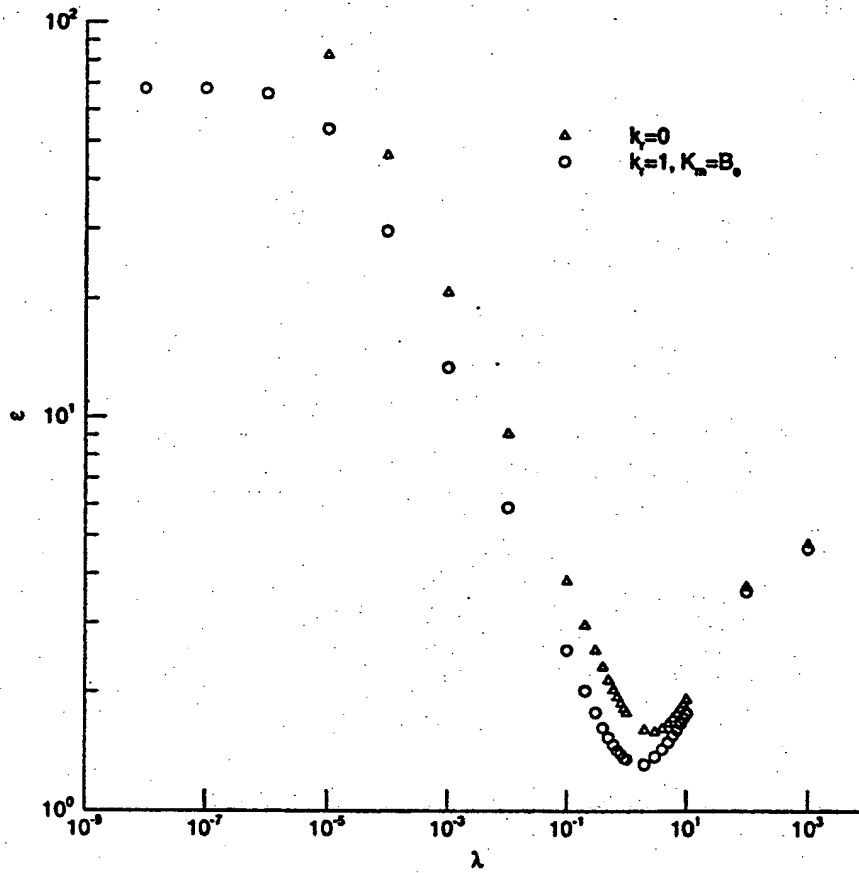

Fig 39

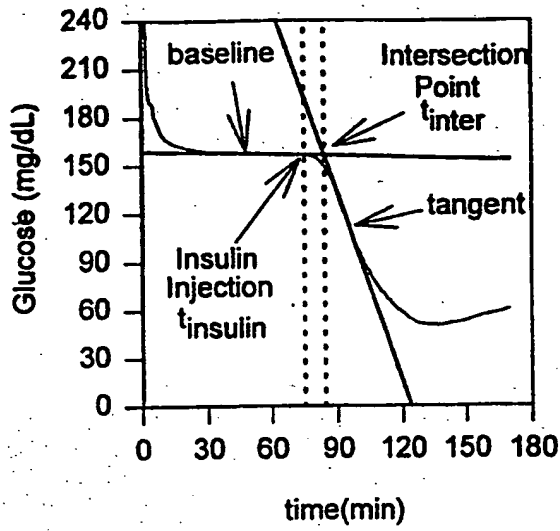

Fig. 40

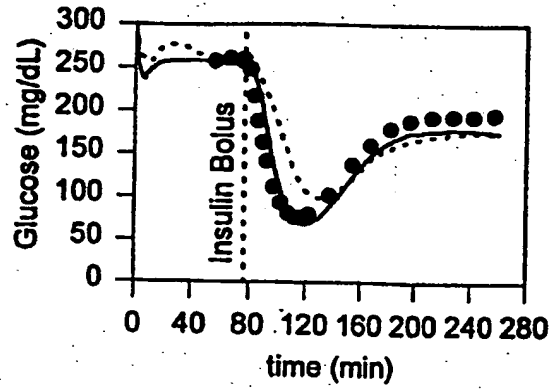

Fig. 41

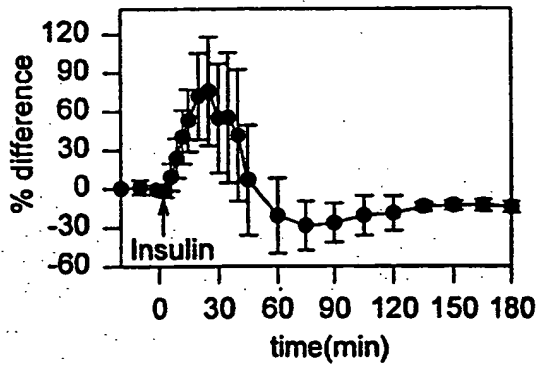

Fig. 42

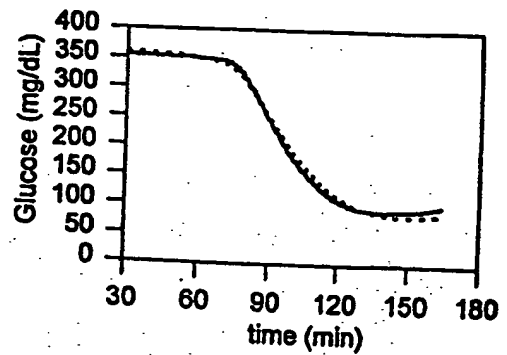

Fig. 43

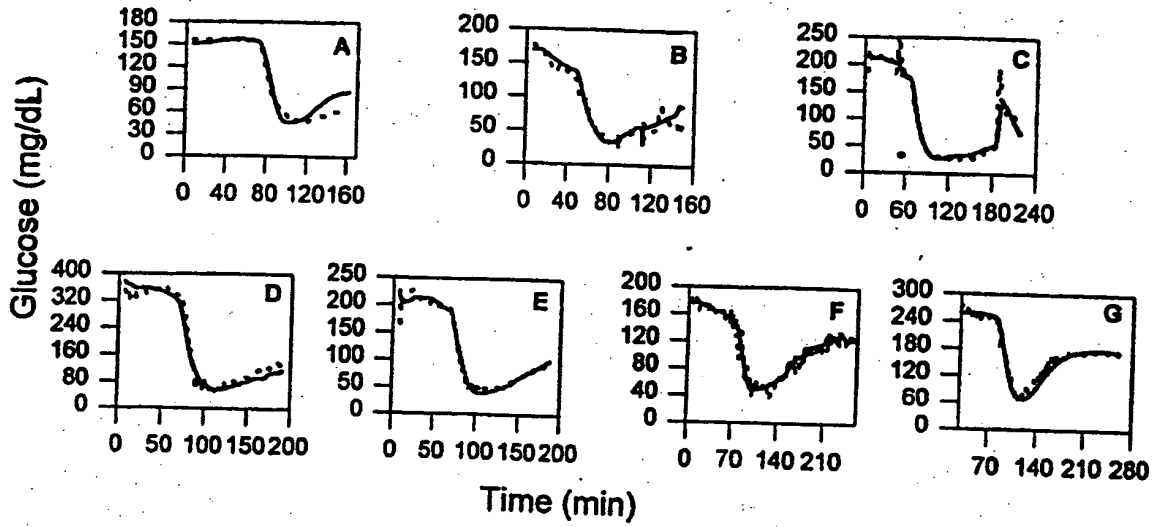

Figure 44

INTERNATIONAL SEARCH REPORT

International Application No

PCT/US 98/25685

A. CLASSIFICATION OF SUBJECT MATTER
IPC 6 A61B5/00

According to International Patent Classification (IPC) or to both national classification and IPC

B. FIELDS SEARCHED

Minimum documentation searched (classification system followed by classification symbols)
IPC 6 A61B

Documentation searched other than minimum documentation to the extent that such documents are included in the fields searched

Electronic data base consulted during the international search (name of data base and, where practical, search terms used)

C. DOCUMENTS CONSIDERED TO BE RELEVANT

Category *	Citation of document, with indication, where appropriate, of the relevant passages	Relevant to claim No.
A	US 5 593 852 A (HELLER ADAM ET AL) 14 January 1997	1-5, 11-15, 23 25-30, 33
A	see column 3, line 66 - column 4, line 51 see column 11, line 50 - line 65 see column 13, line 9 - line 49	
A	WO 91 01680 A (PALTI YORAM PROF) 21 February 1991	1-4, 11-14 23-29, 33
A	see page 5, line 25 - page 7, line 4 see page 9, line 14 - page 10, line 2 see page 16, line 7 - page 18, line 12 see figures 1, 4, 6	
A	US 3 837 339 A (AISENBERG S ET AL) 24 September 1974	1-4, 11-14 22-29, 33
A	see column 1, line 58 - column 2, line 14 see column 8, line 20 - line 34	

Further documents are listed in the continuation of box C.

Patent family members are listed in annex.

* Special categories of cited documents:

- "A" document defining the general state of the art which is not considered to be of particular relevance
- "E" earlier document but published on or after the international filing date
- "L" document which may throw doubts on priority claim(s) or which is cited to establish the publication date of another citation or other special reason (as specified)
- "O" document referring to an oral disclosure, use, exhibition or other means
- "P" document published prior to the international filing date but later than the priority date claimed

- "T" later document published after the international filing date or priority date and not in conflict with the application but cited to understand the principle or theory underlying the invention
- "X" document of particular relevance; the claimed invention cannot be considered novel or cannot be considered to involve an inventive step when the document is taken alone
- "Y" document of particular relevance; the claimed invention cannot be considered to involve an inventive step when the document is combined with one or more other such documents, such combination being obvious to a person skilled in the art.
- "A" document member of the same patent family

Date of the actual completion of the international search

12 April 1999

Date of mailing of the international search report

20/04/1999

Name and mailing address of the ISA

European Patent Office, P.B. 5818 Patentlaan 2
NL - 2280 HW Rijswijk
Tel. (+31-70) 340-2040, Tx. 31 651 epo nl,
Fax: (+31-70) 340-3016

Authorized officer

Martelli, L

INTERNATIONAL SEARCH REPORT

Information on patent family members

International Application No

PCT/US 98/25685

Patent document cited in search report	Publication date	Patent family member(s)	Publication date
US 5593852 A	14-01-1997	US 5356786 A	18-10-1994
		AU 3501695 A	22-03-1996
		EP 0778897 A	18-06-1997
		JP 10505421 T	26-05-1998
		WO 9606947 A	07-03-1996
WO 9101680 A	21-02-1991	US 5101814 A	07-04-1992
		AT 134120 T	15-02-1996
		CA 2042373 A	12-02-1991
		DE 69025400 D	28-03-1996
		DE 69025400 T	19-09-1996
		EP 0461207 A	18-12-1991
		US 5368028 A	29-11-1994
		US 5190041 A	02-03-1993
		US 3837339 A	24-09-1974

INTERNATIONAL SEARCH REPORT

International application No.

PCT/US 98/25685

Box I Observations where certain claims were found unsearchable (Continuation of Item 1 of first sheet)

This International Search Report has not been established in respect of certain claims under Article 17(2)(a) for the following reasons:

1. Claims Nos.:
because they relate to subject matter not required to be searched by this Authority, namely:

2. Claims Nos.: 34
because they relate to parts of the International Application that do not comply with the prescribed requirements to such an extent that no meaningful International Search can be carried out, specifically:
This international application contains six claim sheets (see box VIII of form PCT/RO/101). Since the text of claim 34 is not complete, this claim has not been searched.
3. Claims Nos.:
because they are dependent claims and are not drafted in accordance with the second and third sentences of Rule 6.4(a).

Box II Observations where unity of invention is lacking (Continuation of item 2 of first sheet)

This International Searching Authority found multiple inventions in this international application, as follows:

1. As all required additional search fees were timely paid by the applicant, this International Search Report covers all searchable claims.
2. As all searchable claims could be searched without effort justifying an additional fee, this Authority did not invite payment of any additional fee.
3. As only some of the required additional search fees were timely paid by the applicant, this International Search Report covers only those claims for which fees were paid, specifically claims Nos.:
4. No required additional search fees were timely paid by the applicant. Consequently, this International Search Report is restricted to the invention first mentioned in the claims; it is covered by claims Nos.:

Remark on Protest

The additional search fees were accompanied by the applicant's protest.

No protest accompanied the payment of additional search fees.

THIS PAGE BLANK (USPTO)

**This Page is Inserted by IFW Indexing and Scanning
Operations and is not part of the Official Record**

BEST AVAILABLE IMAGES

Defective images within this document are accurate representations of the original documents submitted by the applicant.

Defects in the images include but are not limited to the items checked:

- BLACK BORDERS
- IMAGE CUT OFF AT TOP, BOTTOM OR SIDES
- FADED TEXT OR DRAWING
- BLURRED OR ILLEGIBLE TEXT OR DRAWING
- SKEWED/SLANTED IMAGES
- COLOR OR BLACK AND WHITE PHOTOGRAPHS
- GRAY SCALE DOCUMENTS
- LINES OR MARKS ON ORIGINAL DOCUMENT
- REFERENCE(S) OR EXHIBIT(S) SUBMITTED ARE POOR QUALITY
- OTHER: _____

IMAGES ARE BEST AVAILABLE COPY.

As rescanning these documents will not correct the image problems checked, please do not report these problems to the IFW Image Problem Mailbox.

THIS PAGE BLANK (USPTO)